

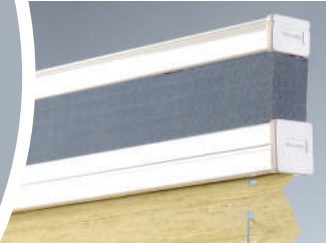

9.1.12

# Plì 353/3



1:1

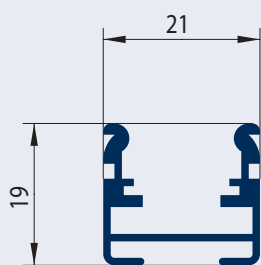

Art. 355

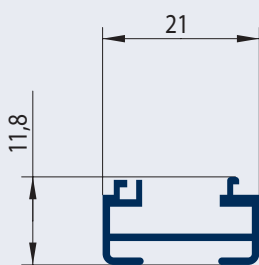

Art. 357

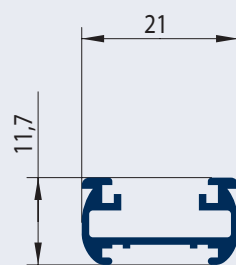

Art. 358

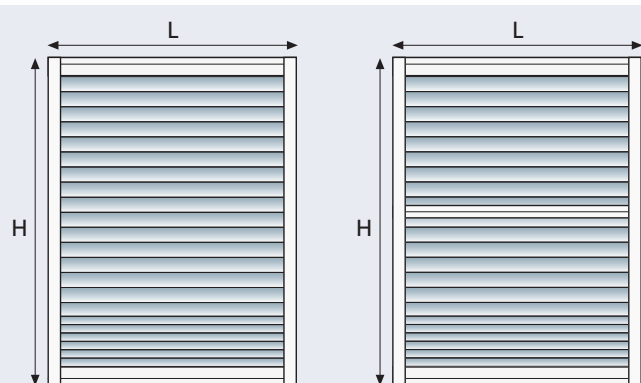

L max: 150 cm

H max: 150/220 cm

L max: 150 cm

H max: 150/220 cm

**USE**

**UTILIZZO - USE - USO  
USO - UTILISATION - ANWENDUNG  
GEBRUIK - ИСПОЛЬЗОВАНИЕ**

## SISTEMA PER TENDE PLISSETTATE CON PIEGHE DA 20 mm

Indicato per installazioni domestiche e professionali.

Scorrimento verticale, inclinato.

Indicato per tende filtranti e/o semioscuranti max 150x150 cm.

Azionamento manuale con arresto in qualsiasi posizione.

Disponibile con tessuto singolo o doppio.

Indicato per serramenti trapezoidali e triangolari.

L'installazione, preferibilmente su serramento o direttamente a soffitto, è con supporti a scatto che facilitano la rimozione del profilo.

Supporti di fissaggio a scatto in acciaio nichelato.

## PLEATED BLIND SYSTEM WITH 20 mm PLEATS

Suitable for domestic and professional installations.

Vertical and sloping sliding.

Suitable for filtering and semi-dimming blinds 150x150 cm max.

Manual operating with stop in any position.

Available with single or double fabrics.

Suitable for trapezoidal or triangular frames.

Installation, preferably on the frame or directly on the ceiling, is by click supports that facilitate track removal.

## SISTEMA DE CORTINAS PLISADAS CON PLIEGUES DE 20 mm

Indicado para instalaciones domésticas y profesionales.

Deslizamiento vertical o inclinado.

Indicado para cortinas filtrantes o semioscurecientes máx. 150 x 150 cm.

Funcionamiento manual con la parada en cualquier posición.

Disponibile con los tejidos simples o dobles.

Conveniente para los herramientas trapezoidales o triangulares.

La instalación, preferiblemente en ventana o directamente en el techo, se efectúa con soportes a presión que facilitan el desmontaje del perfil.

## SISTEMA PARA CORTINAS PLISSADAS COM PREGAS DE 20 mm

Indicado para instalações domésticas e profissionais.

Deslizamento vertical e inclinado. Indicado para cortinas filtrantes e de semi-escurecimento máx 150x150 cm.

Funcionamento manual com batente em alguma posição.

Disponível com únicas ou telas dobro.

Apropriado para frames trapezoidalmente ou triangulares.

A instalação, de preferência no caixilho ou directamente no tecto, é feita com suportes de pressão que facilitam a remoção do perfil.

## SYSTÈME POUR STORES PLISSÉS AVEC PLIS DE 20 mm

Conseillés pour locaux domestiques et professionnels.

Coulissement vertical, incliné.

Indiqué pour stores filtrants et semi-occultants max 150x150 cm.

Actionnement manuelle avec l'arrêt en toute position.

Disponible avec les tissus simples ou doubles.

Approprié des trames trapézoïdales ou triangulaires.

L'installation, de préférence sur croisée ou directement au plafond, est réalisée sur supports encliquetable qui facilitent le retrait du profil.

## PLISSEE MIT 20 mm-FALTEN

Für den privaten Haushalt und den Arbeitsbereich.

Vertikale oder schräge Führung.

Für halbtransparente und/oder halbdunkelnde Plissee geeignet max. 150x150 cm.

Manuelle Bedienung mit Halt in irgendeiner Position.

Verfügbar mit einfachen oder doppelten Geweben.

Passend für die trapezoiden oder dreieckigen Fenster.

Die Montage erfolgt vorzugsweise am Fenster oder direkt an der Decke mit Klips aus vernickeltem Stahl, so dass das Profil leicht zu entfernen ist.

## PLISSÉSYSTEEM MET 20 mm PLOOIBREEDTE

Voor privaat en professioneel gebruik.

Toepassing voor verticale en schuine ramen.

Gebruik met verduisterende en filterende stoffen max. 150 cm x 150 cm.

Handbediend met eindstop in elke positie.

Beschikbaar met enkele of dubbele stoffen.

Geschikt voor trapezoidale of driehoekige frames.

Plaatsing op het raam, of tegen de wand of het plafond.

## СИСТЕМА ДЛЯ ПЛИССЕРОВАННЫХ ШТОР СО СКЛАДКАМИ 20 мм

Система для плиссированных штор со складками 20 мм.

Предназначена для установки в жилых и офисных помещениях.

Вертикальное и наклонное открытие.

Предназначена для фильтрующих и полузатемняющих штор макс. 150x150 см.

Ручной привод с стопом в любом положении.

Доступно с одиночными или двойными тканями.

Соответствующе для трапецоидальных или треугольных.

Установка, желательна на оконную раму или непосредственно на потолок, выполняется при помощи защелкивающихся суппортов, облегчающих демонтаж профиля.

Суппорты из никелированной стали.



9.1.14

# PI 353/3



## CARATTERISTICHE TECNICHE - SPECIFICATIONS CARACTERÍSTICAS-CARACTERÍSTICAS-CARACTÉRISTIQUES EIGENSCHAFTEN-KARAKTERISTIEKEN-ХАРАКТЕРИСТИКИ

- Profilo superiore ed inferiore in lega d'alluminio estrusa 6060 T6-UNI 8278
- Profilo superiore Larghezza 21 mm Altezza 19 mm
- Profilo inferiore Larghezza 21 mm Altezza 19 mm
- Profilo porta tessuto in PVC estruso
- Finitura superficiale:  
verniciatura poliesteri bianco RAL 9016 lucido; nero RAL 9005 lucido; vaniglia; argento/grigio  
altri colori a richiesta
- Accessori in acetilica autolubrificante
- Arresto in poliammide antiusura
- 6060 T6 UNI 8278 extruded aluminium alloy upper and lower track
- Upper track: Width 21 mm; Height 19 mm
- Lower track: Width 21 mm; Height 19 mm
- Extruded PVC fabric holder track
- Surface finish:  
RAL 9016 white polished; RAL 9005 black polished; vanilla; silver/grey  
available on request
- Self-lubricating acetylic accessories
- Wearproof polyamide stop
- Perfil superior e inferior en aleación de aluminio extruido 6060 T6-UNI 8278
- Perfil superior: Anchura 21 mm - Altura 19 mm
- Perfil inferior: Anchura 21 mm - Altura 19 mm
- Perfil portatejido en PVC extruido
- Acabados de la superficie:  
pintura poliéster blanca RAL 9016 brillante; negra RAL 9005 brillante; vainilla; plata/gris  
otros colores bajo petición
- Accesorios en acetálico autolubrificante
- Freno de poliamida antiroce
- Perfis superior e inferior de liga de alumínio extrudido 6060 T6-UNI 8278
- Perfis superior: Largura 21 mm; Altura 19 mm
- Perfis inferior: Largura 21 mm; Altura 19 mm
- Perfil porta-tecido em PVC extrudido
- Acabamento superficial:  
tinta de poliéster branca RAL 9016 polido; preta RAL 9005 polido; vermelha; prateado/cinza  
outras cores a pedido
- Batente de paragem de poliamida anti-desgaste
- Profil supérieur et inférieur en alliage d'aluminium extrudé 6060 T6-UNI 8278
- Profil supérieur: Largeur 21 mm; Hauteur 19 mm
- Profil inférieur: Largeur 21 mm; Hauteur 19 mm
- Profil porte-tissu en PVC extrudé
- Finition superficielle:  
peinture polyester blanc RAL 9016 brillant; noir RAL 9005 brillant; vanille; argent/gris  
autres couleurs sur demande
- Accessoires en résine d'acétal autolubrificante
- Arrêt en polyamide anti-usure
- Oberes und unteres Profil aus eloxiertem Aluminium 6060 T6-UNI 8278
- Oberes Profil: Breite 21 mm; Höhe 19 mm
- Unteres Profil: Breite 21 mm; Höhe 19 mm
- Stoffhalteprofil aus extrudiertem PVC
- Oberflächen-Finish:  
Polyesterlackierung Weiß RAL 9016 poliert; Schwarz RAL 9005 poliert; Vanille; silber/grau  
andere Farben auf Anfrage
- Zubehör aus selbstschmierendem Acetal
- Arretierung aus stoßfestem Polyamid
- 6060 T6 UNI 8278 aluminium boven- en onderprofiel
- Bovenprofiel: Breedte 21 mm - hoogte 19 mm
- Onderprofiel: Breedte 21 mm - hoogte 19 mm
- PVC profiel voor de bevestiging van de stof
- Oppervlaktebehandeling: RAL 9016 wit polyesterlak gepolijst; RAL 9005 zwart polyesterlak gepolijst - vanille RAL 1013 zilver en brons geanodiseerd  
andere kleuren op aanvraag
- Zelfsmerende acetyl onderdelen
- Polyamide eindstop
- Верхний и нижний профиль из экструдированного алюминия 6060 T6 UNI 8278
- Ширина верхнего профиля 21 мм; Высота 19 мм
- Ширина нижнего профиля 21 мм; Высота 19 мм
- Несущий штору профиль из экструдированного ПВХ
- Отделка поверхности:  
полиэфирная окраска в белый цвет RAL 9016 полированный, в черный цвет RAL 9005 полированный; ваниль; серебристый/серый  
другие цвета по запросу
- Аксессуары из самосмазывающейся ацеталовой пластмассы
- Блокатор корда из износостойкого полиамида



APERTURA - OPENING - APERTURA - ABERTURA - OUVERTURE - AUFZUG - OPEENEN - ОТКРЫТИЕ

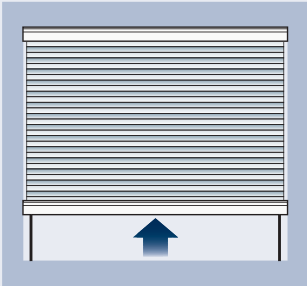

Versione standard  
/ Standard version

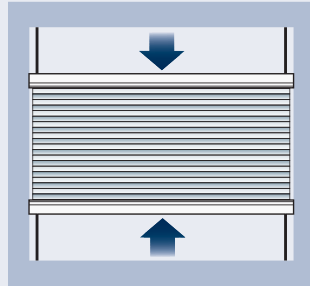

Versione B  
/ B version

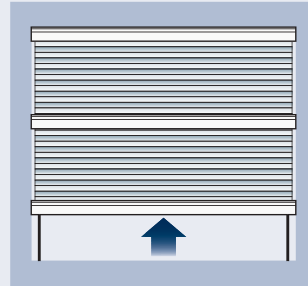

Versione C  
/ C version

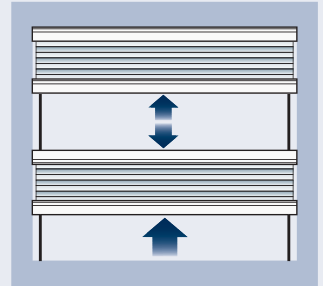

Versione D (L max 120 cm)  
/ D version (L max 120 cm)

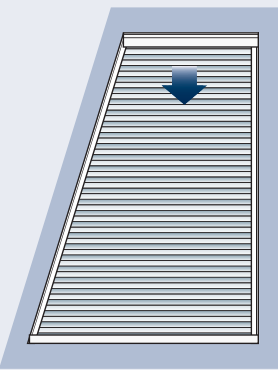

Versione E  
/ E version

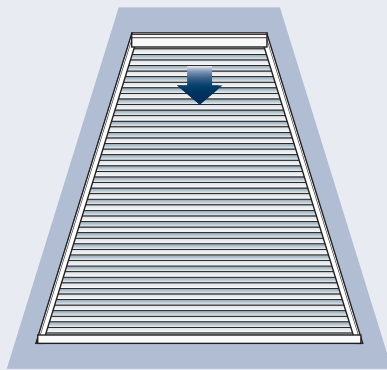

Versione F  
/ F version

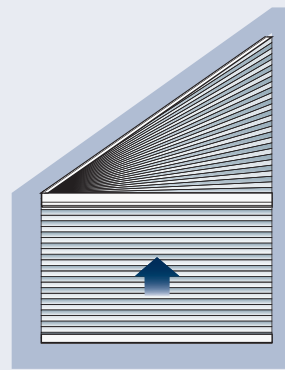

Versione G  
/ G version

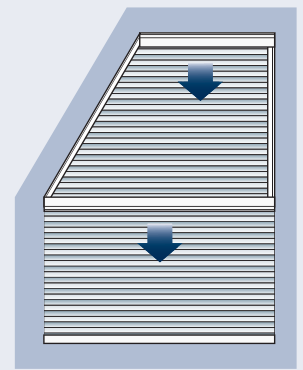

Versione H  
/ H version

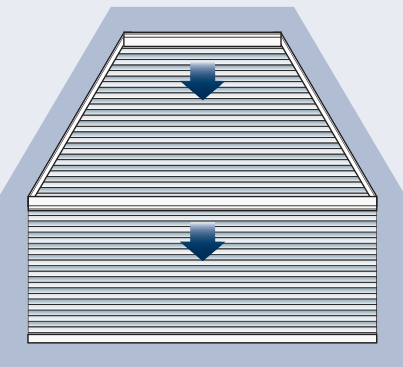

Versione I  
/ I version

INGOMBRI - OVERALL DIMENSIONS - ESPESORES - DIMENSÃO - ENCOMBREMMENT - RAUMBEDARF - ПАККЕТ - ГАБАРИТЫ

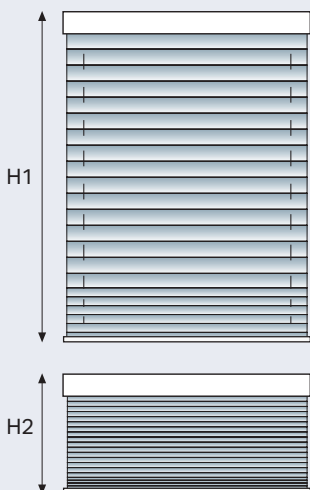

L max 150 cm  
H1 max 150/220 cm

L min 15 cm

H1		H2
50 cm	≈	5 cm
100 cm	≈	6 cm
150 cm	≈	7 cm
220 cm	≈	8,5 cm



L max 150 cm  
H1 max 150/220 cm

L min 15 cm

H1		H2
50 cm	≈	9 cm
100 cm	≈	11 cm
150 cm	≈	13 cm
220 cm	≈	16 cm



9.1.16

# Plì 353/3

INSTALLAZIONE - INSTALLATION - INSTALACIÓN - INSTALAÇÃO - INSTALLATION - INSTALLATION - INSTALLATIE - УСТАНОВКА

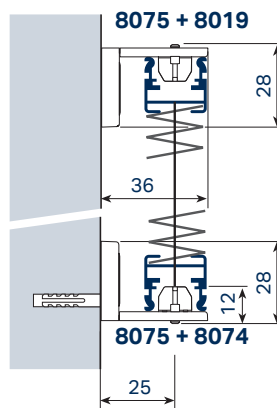
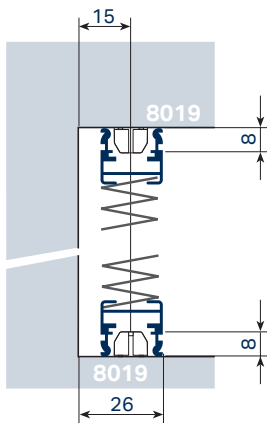
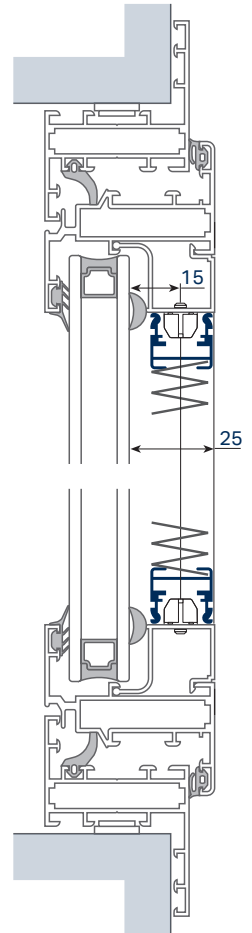
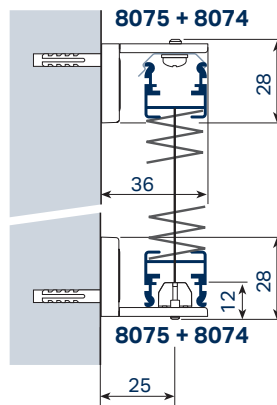
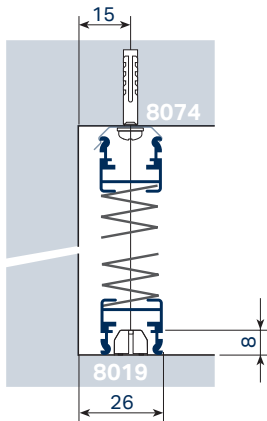

TENDE GUIDATE - GUIDED BLINDS - CORTINAS CON GUÍAS - CORTINAS COM GUIAS -  
PLISSÉ GUIDÉ - PLISSEE VERPANT - PLISSÉ MET ZIJGELEIDING - ШТОРЫ С НАПРАВЛЯЮЩИМИ

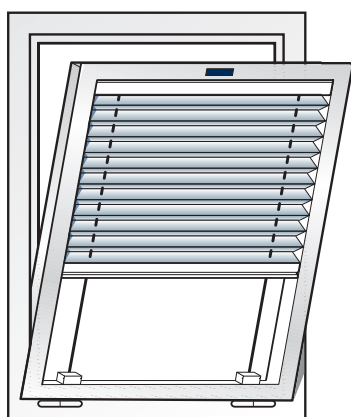

max 15°

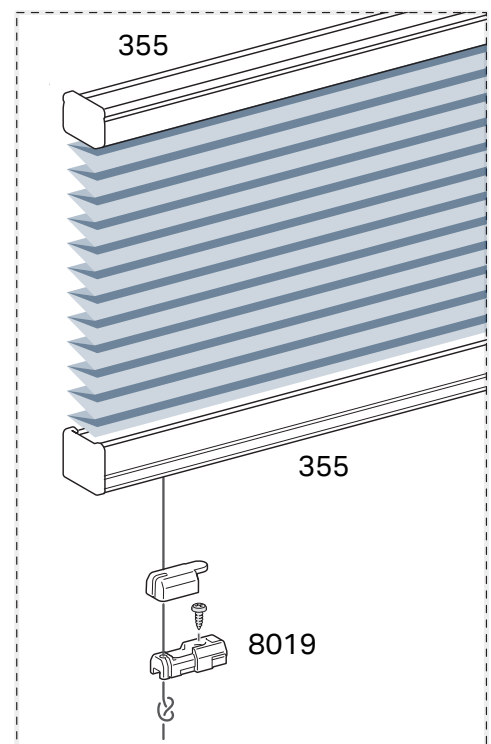

- Per l'applicazione su finestre inclinate e/o basculanti (non disponibile nelle versioni B, G e 366/..)
- For use on raking and/or swinging window (not available in versions B, G and 366/..)
- Para aplicación en ventanas inclinadas o basculantes (no disponible en las versiones B, G y 366/..)
- Para aplicação em janelas inclinadas e/ou basculantes (não disponível nas versões B, G e 366/..)
- Pour l'utilisation sur chassis ouvrants (non disponible dans les versions B, G et 366/..)
- Für Dachschrägen und Kippfenster (nicht verfügbar in den Versionen B, G und 366/..)
- Voor gebruik op kantelende ramen (niet beschikbaar in versies B, G en 366/..)
- Для установки на наклонных или качающихся окнах (не доступны в версиях B, G и 366/..)

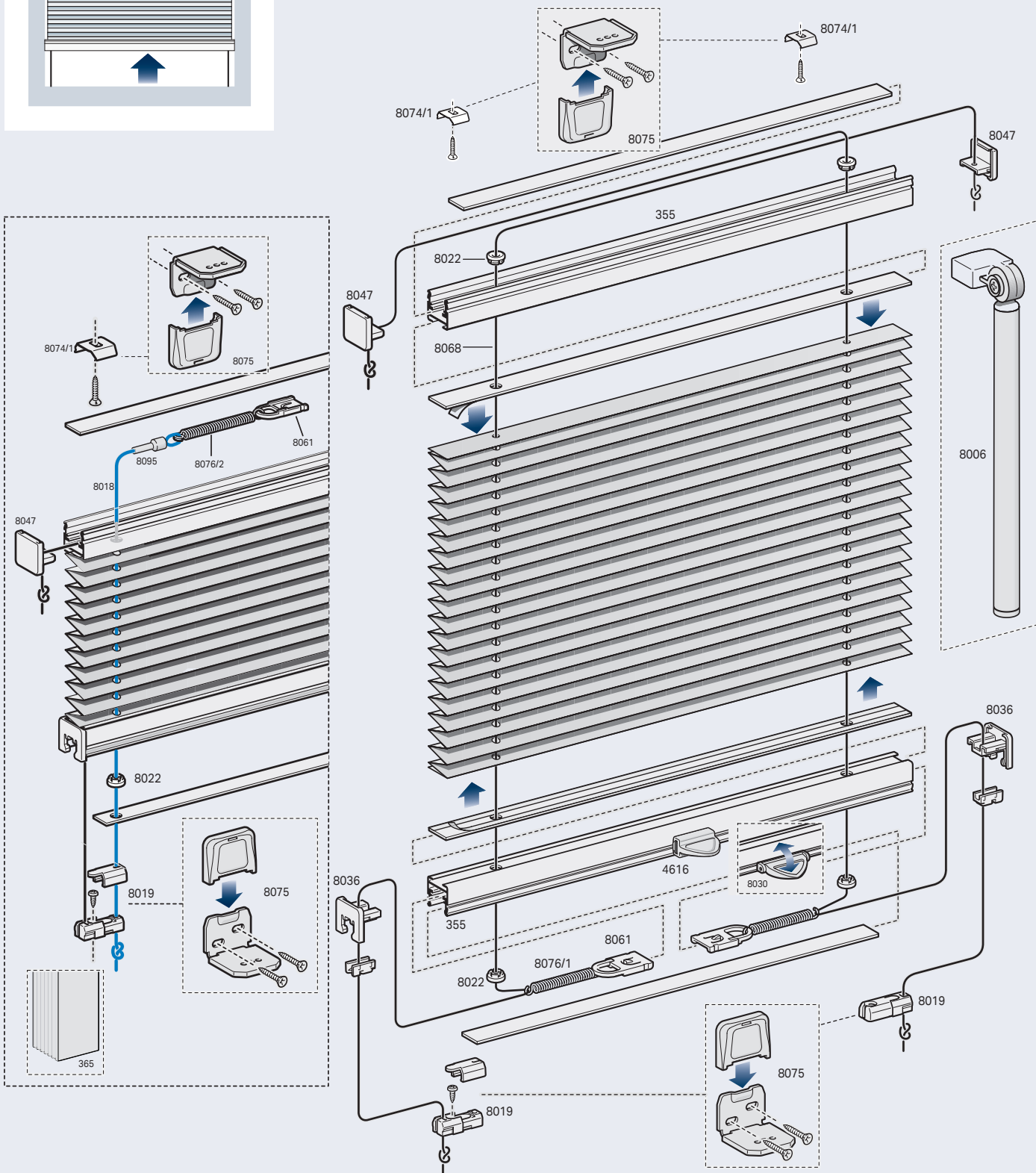
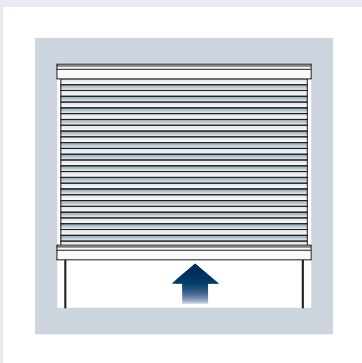



9.1.18

# Più 353/3

