



VENIWOOD
WOODEN VENETIAN BLINDS

MOTTURA
SOLUZIONI ALLA LUCE DEL SOLE

Veniwood

Il fascino del design incontra il calore del legno, rendendo la tenda veneziana un vero oggetto di prestigio per le soluzioni d'arredo più esclusive.

The charm of design meets the warmth of wood, taking the venetian blind up a notch: a real prestigious object, intended for exclusive decorating solutions.

CIÒ CHE È NATURALE DURA NEL TEMPO

Da tempo il legno è un fedele compagno dell'uomo, garanzia di calore nelle fredde notti invernali.

Oggi, grazie alla sua versatilità e durabilità nel tempo, risponde ad esigenze architettoniche e quotidiane con eleganza, ricchezza di dettagli, fascino e personalità. Valorizza gli spazi giocando con la luce in modo autentico e sostenibile.

Introducendo il legno nella struttura e nelle funzionalità della vostra casa, la doterete di elementi ricchi di vitalità e trasformerete ogni ambiente in uno spazio armonioso.

WHAT IS NATURAL SLATS OVER TIME

Wood has long been a faithful companion to humanity, providing warmth on cold winter nights. Today, thanks to its versatility and durability, it meets architectural and everyday needs with elegance, rich detail, charm, and personality. It enhances spaces by playing with light in an authentic and sustainable way. By incorporating wood into the structure and functionality of your home, you will infuse it with elements full of vitality and transform every room into a harmonious space.

FORESTE CERTIFICATE

È fondamentale per la salvaguardia delle risorse del pianeta un approccio culturale nuovo, che sostenga le regole di un'economia circolare, contrapposta all'economia di scala. Il legno delle Veniwood proviene da foreste gestite in maniera corretta e responsabile secondo rigorosi standard ambientali, sociali ed economici. I prodotti Veniwood sono certificati Certification for the FSC® Chain of Custody Control System (standard FSC-STD-40-004, v3.0).

CERTIFIED FORESTS

It is essential for the protection of the planet's resources a new cultural approach supporting the rules of a circular economy, as opposed to the economy of scale. The wood used for these venetian blinds comes from forests that are managed correctly and responsibly according to strict environmental, social and economic standards. Veniwood products are certified for the FSC® Chain of Custody Control System with standard FSC-STD-40-004, v3.0.

MOTTURA



I plus

SMART HOME & AUTOMATION

Oggi, vivere i propri ambienti in modo intelligente significa poter gestire luce, privacy e comfort con la massima semplicità.

Mottura adotta lo **standard Matter integrato** nei propri motori, il linguaggio universale della smart home moderna, garantendo la compatibilità con i principali ecosistemi come Apple Home, Google Home e Amazon Alexa. Con un semplice comando vocale, tramite smartphone, è possibile controllare le tende in modo intuitivo, anche da remoto.

Cuore del sistema è **M2Net 2.0**, il protocollo intelligente sviluppato da Mottura per mettere in comunicazione motori, sensori e dispositivi di controllo attraverso tecnologia radio bidirezionale e bus digitale.

Attraverso l'**app easyMoT**, l'utente può gestire in modo semplice e immediato tutte le funzioni del sistema direttamente dal proprio smartphone, offrendo libertà di controllo e accesso ai propri ambienti ovunque ci si trovi.

Today, living in your home the smart way means being able to manage lighting, privacy, and comfort with the utmost ease.

Mottura has adopted the **Matter standard**, the universal language of the modern smart home, integrated into its motors, ensuring compatibility with major ecosystems such as Apple Home, Google Home, and Amazon Alexa. With a simple voice command or via smartphone, you can control your blinds intuitively, even remotely.

The heart of the system is **M2Net 2.0**, the smart protocol developed by Mottura to connect motors, sensors, and control devices via two-way radio technology and a digital bus.

Through the **easyMoT app**, users can easily and instantly manage all system functions directly from their smartphone, offering freedom of control and access to their living spaces wherever they are.

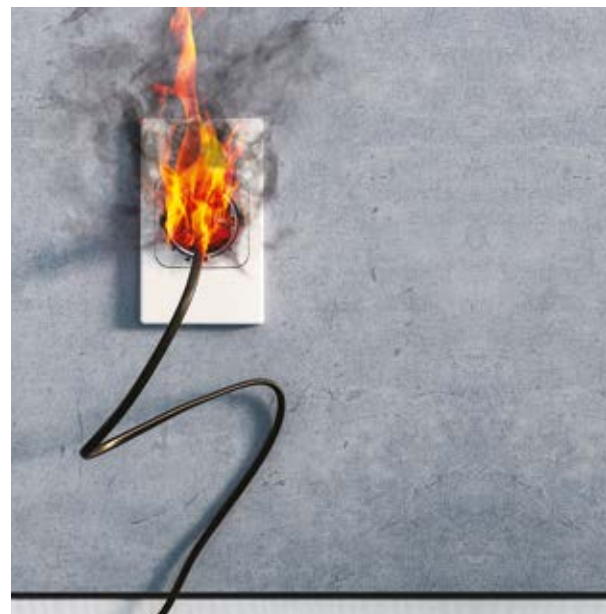

QUITFIRE

Le veneziane in legno Veniwood sono trattate, su richiesta, con diversi tipi di vernici ignifughe e perciò soddisfano le normative standard in materia di sicurezza antincendio offrendo sicurezza a lungo termine. Sono disponibili due trattamenti: il trattamento ignifugo (solo vernice) o il trattamento Quitfire (legno e vernice) concesso, quest'ultimo, da un annesso laboratorio italiano certificato. In conformità alla UNI 9177, a Veniwood viene attribuita la classe di reazione al fuoco 1.

Veniwood blinds are treated, on demand, with different types of fire-retardant paints and so they meet fire-safety standards regulations offering long-term safety. Two treatments are available: the fire-retardant treatment (paint only) or the Quitfire treatment (wood and paint) granted, the latter, by an Italian certified laboratory. In compliance with UNI 9177, Veniwood is assigned the class of reaction to fire 1.

HUMIDITY ANTIBACTERIAL

Grazie ad una finitura acrilica trasparente igienizzante e una poliuretanic pigmentata igienizzante applicate con una vernice, tutte le veneziane in legno possiedono qualità antibatteriche. Su richiesta, è possibile applicare un trattamento anti umidità, che consente di evitare muffe, delaminazioni e corrosione così da rendere applicabili le veneziane ad ambienti soggetti ad alto tasso di umidità come bagni o arredamenti in ambiente navale.

Thanks to a transparent, sanitizing acrylic and a pigmented, sanitizing polyurethane finish, all the wooden blinds have antibacterial properties. Upon request, a moisture-resistant treatment can be applied to prevent mold, delamination, and corrosion, making the blinds suitable for use in high-humidity environments such as bathrooms or naval interiors.



1

2

3



Classico

Tipo di legno: Abachiwood
Spessore della lama: 3 mm
È possibile realizzare colori speciali su richiesta

Type of wood: Abachiwood
Slat thickness: 3 mm
It is possible to make colour on request

| | 25 mm | 35 mm |
|--|-------|-------|
|--|-------|-------|

| | | |
|---------------------------|--|--|
| PESO WEIGHT | 1,8 kg/m ² | 2 kg/m ² |
| FINITURA FINISH | Scaletta a filo Scaletta a nastro 16 mm | Scaletta a filo Scaletta a nastro 16 mm |
| L max | 260 cm | 260 cm |
| PESO TENDA CURTAIN WEIGHT | Max 10 kg | Max 10 kg |

| | 50 mm | 70 mm |
|--|-------|-------|
|--|-------|-------|

| | | |
|-----------------|--|---|
| PESO WEIGHT | 2,1 kg/m ² | 2,1 kg/m ² |
| FINITURA FINISH | Scaletta a filo Scaletta a nastro 10 - 25 - 38 mm | Scaletta a filo Scaletta a nastro 10 - 38 mm |
| L max | 300 cm | 300 cm |



Natura

Tipo di legno: Abachiwood
Spessore della lama: 3 mm
È possibile realizzare colori speciali su richiesta

Type of wood: Abachiwood
Slat thickness: 3 mm
It is possible to make colour on request

| | 50 mm | 70 mm |
|--|-------|-------|
|--|-------|-------|

| | | |
|-----------------|--|---|
| PESO WEIGHT | 2,1 kg/m ² | 2,1 kg/m ² |
| FINITURA FINISH | Scaletta a filo Scaletta a nastro 10 - 25 - 38 mm | Scaletta a filo Scaletta a nastro 10 - 38 mm |
| L max | 300 cm | 300 cm |

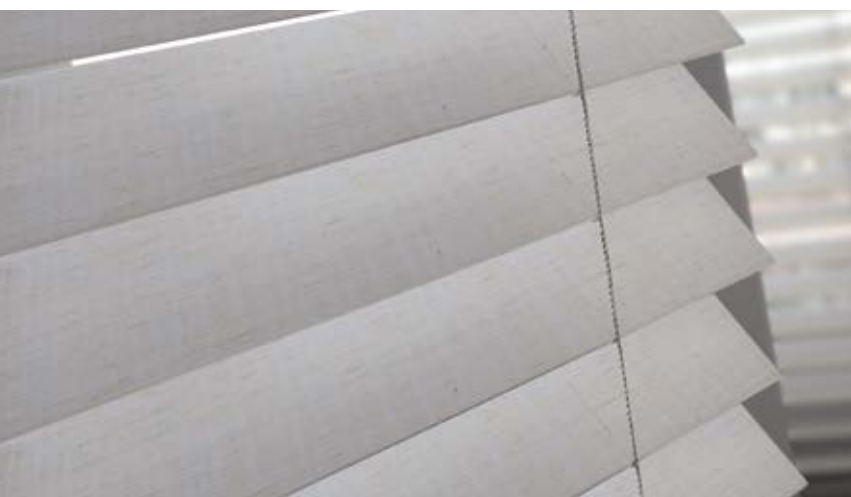

Puro

Tipo di legno: Abachiwood
Spessore della lama: 3 mm
È possibile realizzare colori speciali su richiesta

Type of wood: Abachiwood
Slat thickness: 3 mm
It is possible to make colour on request

| | 50 mm | 70 mm |
|--|-------|-------|
|--|-------|-------|

| | | |
|-----------------|--|---|
| PESO WEIGHT | 2,1 kg/m ² | 2,1 kg/m ² |
| FINITURA FINISH | Scaletta a filo Scaletta a nastro 10 - 25 - 38 mm | Scaletta a filo Scaletta a nastro 10 - 38 mm |
| L max | 300 cm | 300 cm |



Laqué

Tipo di legno: Abachiwood
Spessore della lama: 3 mm
È possibile realizzare colori speciali su richiesta

Type of wood: Abachiwood
Slat thickness: 3 mm
It is possible to make colour on request

| | 50 mm | 70 mm |
|-----------------|---|--|
| PESO WEIGHT | 3,1 kg/m ² | 3,1 kg/m ² |
| FINITURA FINISH | Scaletta a filo Scaletta a nastro 10 - 25 - 38 mm | Scaletta a filo Scaletta a nastro 10 - 38 mm |
| L max | 300 cm | 300 cm |



Siam

Tipo di legno: Bamboo
Spessore della lama: 2 mm
È possibile realizzare colori speciali su richiesta

Type of wood: Bamboo
Slat thickness: 2 mm
It is possible to make colour on request

| | 50 mm | 70 mm |
|-----------------|---|--|
| PESO WEIGHT | 3 kg/m ² | 3 kg/m ² |
| FINITURA FINISH | Scaletta a filo Scaletta a nastro 10 - 25 - 38 mm | Scaletta a filo Scaletta a nastro 10 - 38 mm |
| L max | 240 cm | 240 cm |



Parquet

Tipo di legno: Abachiwood
Spessore della lama: 3 mm
È possibile realizzare colori speciali su richiesta

Type of wood: Abachiwood
Slat thickness: 3 mm
It is possible to make colour on request

| | 50 mm | 70 mm |
|-----------------|---|--|
| PESO WEIGHT | 2,1 kg/m ² | 2,1 kg/m ² |
| FINITURA FINISH | Scaletta a filo Scaletta a nastro 10 - 25 - 38 mm | Scaletta a filo Scaletta a nastro 10 - 38 mm |
| L max | 300 cm | 300 cm |



Graffiti

Tipo di legno: Abachiwood
Spessore della lama: 3 mm
È possibile realizzare colori speciali su richiesta

Type of wood: Abachiwood
Slat thickness: 3 mm
It is possible to make colour on request

| | 50 mm | 70 mm |
|-----------------|---|--|
| PESO WEIGHT | 3 kg/m ² | 3 kg/m ² |
| FINITURA FINISH | Scaletta a filo Scaletta a nastro 10 - 25 - 38 mm | Scaletta a filo Scaletta a nastro 10 - 38 mm |
| L max | 300 cm | 300 cm |

Millerighe

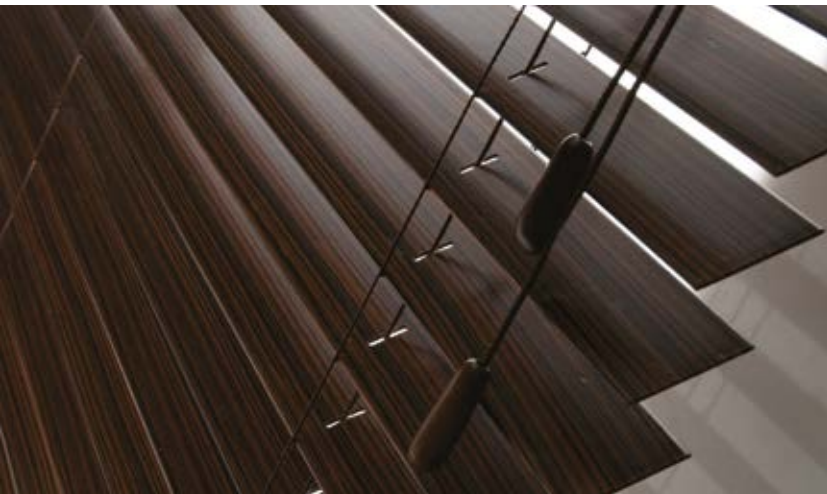

Tipo di legno: Abachiwood
Spessore della lama: 3 mm
È possibile realizzare colori speciali su richiesta

Type of wood: Abachiwood
Slat thickness: 3 mm
It is possible to make colour on request

| | 50 mm | 70 mm |
|-----------------|---|--|
| PESO WEIGHT | 3,1 kg/m ² | 3,1 kg/m ² |
| FINITURA FINISH | Scaletta a filo Scaletta a nastro 10 - 25 - 38 mm | Scaletta a filo Scaletta a nastro 10 - 38 mm |
| L max | 250 cm | 250 cm |

Oceano



Lamella in alluminio
Lamella di legno
Tipo di legno: Abachiwood
Spessore della lama: 3 mm
È possibile realizzare colori speciali su richiesta

Aluminium slat
Wood slat
Type of wood: Abachiwood
Slat thickness: 3 mm
It is possible to make colour on request

| | 50 mm | 70 mm |
|-----------------|--|---|
| PESO WEIGHT | 4 kg/m ² | 5 kg/m ² |
| FINITURA FINISH | Scaletta a filo Scaletta a nastro 10 - 25 - 38 mm | Scaletta a filo Scaletta a nastro 10 - 38 mm |
| L max | 250 cm | 250 cm |

Resistenza all'abrasione Abrasion resistance: UNI EN ISO12947(2) > 45
Resistenza alla luce Light solidity: UNI EN ISO105-B02:2001
Resistenza alla frizione Friction solidity: UNI EN ISO105-X12

IMPACCHETTAMENTO / PACKING

| H | Lamelle in alluminio Aluminium slats (3mm) | | | | | | Lamelle in legno Wood slats (5mm) | | | | | |
|------|--|-----|----------------------|-------------------|-----|-----------------------------|-----------------------------------|----------------------|-------------------|-----|--|--|
| | scaletta nastro ladder tape | | nastro tape 10-25 mm | nastro tape 38 mm | | scaletta filo ladder string | | nastro tape 10-25 mm | nastro tape 38 mm | | | |
| | 50 | 70 | 50 | 50 | 70 | 50 | 70 | 50 | 50 | 70 | | |
| 500 | 114 | 112 | 120 | 120 | 112 | 132 | 126 | 140 | 140 | 126 | | |
| 1000 | 160 | 148 | 168 | 168 | 148 | 202 | 178 | 212 | 212 | 178 | | |
| 1500 | 202 | 184 | 216 | 216 | 184 | 266 | 230 | 284 | 284 | 230 | | |
| 2000 | 243 | 220 | 264 | 264 | 220 | 329 | 282 | 356 | 356 | 282 | | |

Colori del filo per la cucitura delle lamelle
Colors of the thread for the seaming of the slats

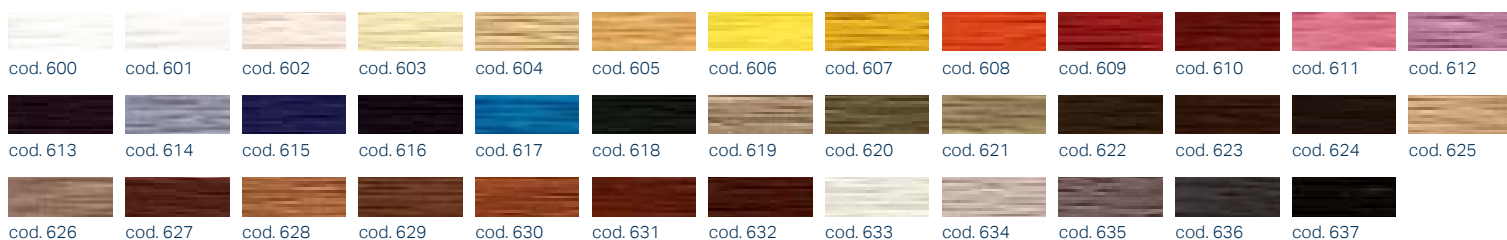

N.B.: I campioni di colore sono indicativi e, per motivi di stampa e di carta, potrebbero leggermente differire dal colore del filo
Color samples are indicative and, for printing and paper reasons, may differ slightly from the color of the thread

COMPONENTI DI SERIE / STANDARD PACK WITH



MANTOVANA VALENCE

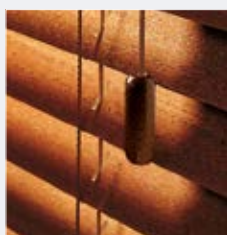

FIOCCO CURTAIN WEIGHT

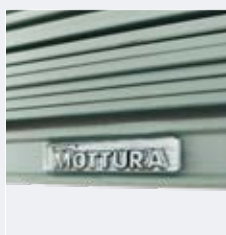

TERMINALE BOTTOM RAIL



CON SCALETTA IN FILO LADDER STRING

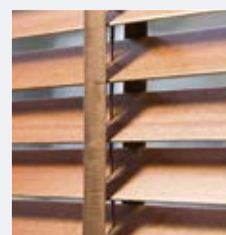

CON SCALETTA A NASTRO LADDER TAPE



PLACCA PLATE

1. AZIONAMENTO MANUALE HAND DRAWN

25-35 mm

- Cassonetto in ferro verniciato 37x37 mm
- Scaletta a filo e a nastro
- Mantovana con attacchi a calamita
- Supporti a chiave parete/soffitto
- 37x37 mm painted iron headbox
- Ladder and string tape
- Pelmet with magnet attachment
- Wall or ceiling support

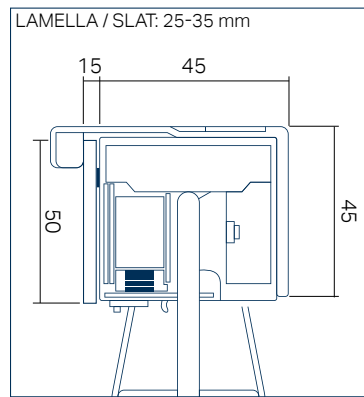

50-70 mm

- Cassonetto in ferro 57x51 mm
- Scaletta a filo e a nastro
- Mantovana con attacchi a calamita
- Supporti a chiave parete/soffitto
- 57x51 mm iron headbox
- Ladder and string tape
- Pelmet with magnet attachment
- Wall or ceiling support

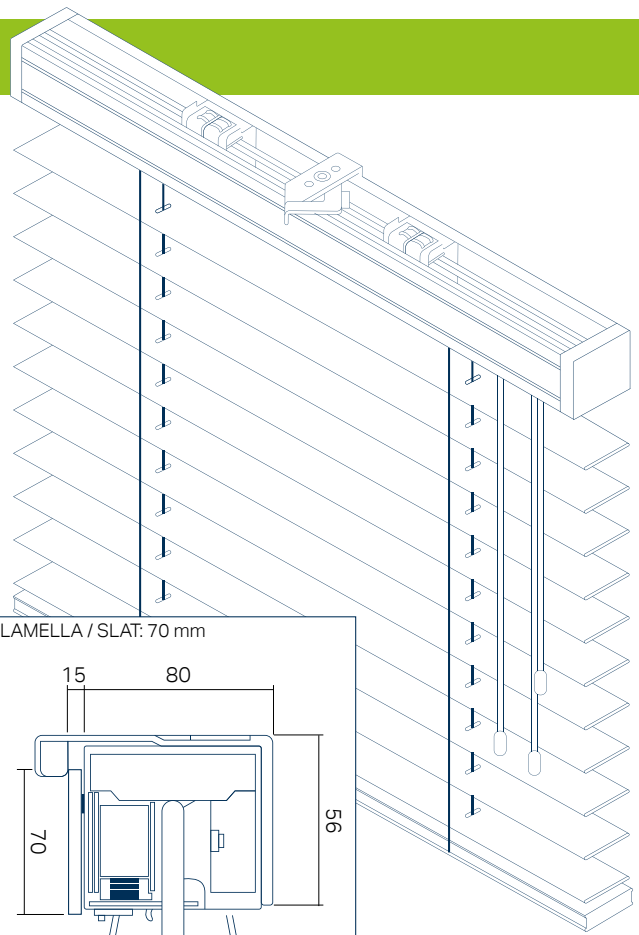
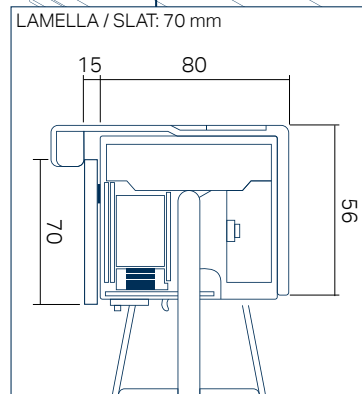
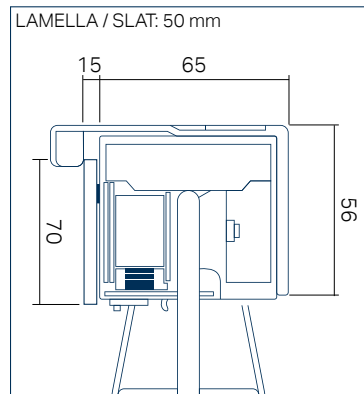

2. AZIONAMENTO AD ARGANELLO CRANK OPERATED

- Cassonetto in ferro 51x57 mm
- Scaletta a filo e a nastro
- Mantovana con attacchi a calamita
- Supporto a soffitto
- Manovella colori bianco e bronzo - h 123 - 173 - 223 cm
- Peso max 18 kg
- Iron headbox 51x57 mm
- Ladder and string tape
- Pelmet with magnet attachment
- Ceiling support
- White and bronze winch - H 123 - 173 - 223 cm
- Max weight 18 kg

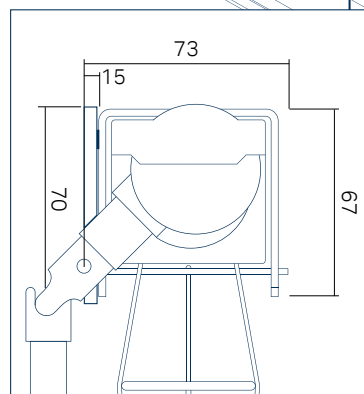
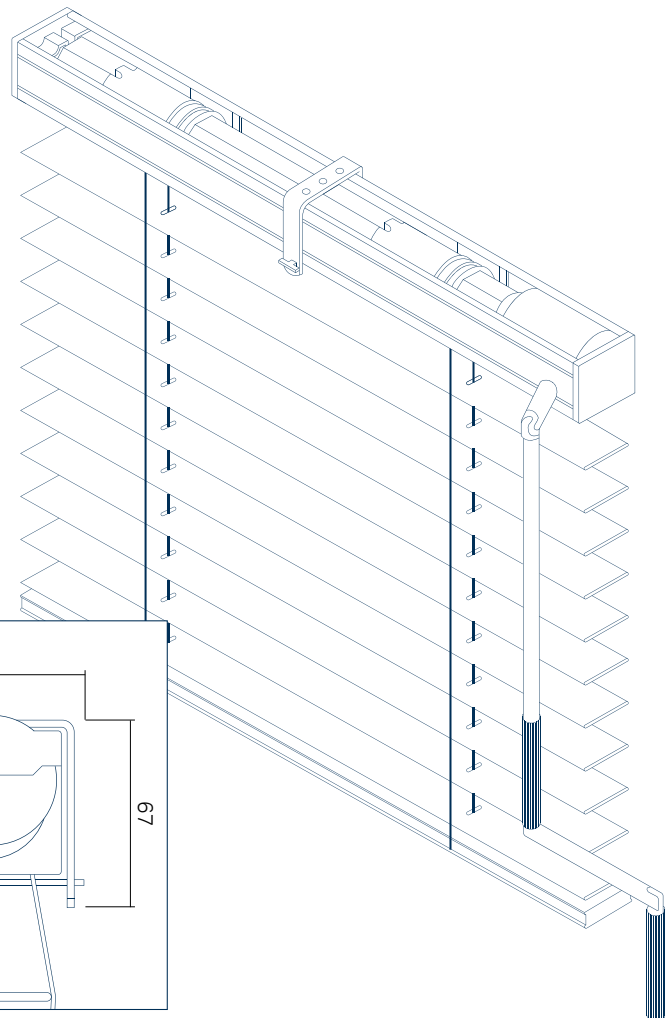

3. AZIONAMENTO A MOTORE MOTORIZED SYSTEMS

Motore meccanico, motore radio o M2Net.

- Cassonetto in ferro 51x57 mm
- Scaletta a filo e a nastro
- Mantovana con attacchi a calamita
- Supporto a soffitto
- Per attacco a parete usare supporti: cm 10 - 12 - 15 (bianco, grigio e nero) cm 15 - 20 (zincato)

DIMENSIONI TENDA:

- motore meccanico VZ105: min 55 cm
- motore radio VZ118: min 66 cm
- M2Net VZ119: min 73 cm

Automatismi

Motori meccanici - VZ105

- 5096 Pulsante singolo a parete
- 5098 Pulsante
- 5158 Ricevitore R.F. per motori 230 Vac

Motori radio - VZ118

- 5143 Trasmettitore R.F. 1 sistema
- 5155 Trasmettitore R.F. 15 sistemi
- 5148 Trasmettitore R.F. a parete 1 sistema
- 5167 Trasmettitore a parete R.F. 15 sistemi
- 5168 Trasmettitore timer a parete R.F. 1 canale

M2Net - VZ119

- 5474B Trasmettitore touch 1-4 sistemi bianco
- 5455B Trasmettitore touchscreen 15 sistemi bianco
- 5459B Trasmettitore touchscreen 99 sistemi bianco
- 5484B Trasmettitore touch parete 4 sistemi bianco estraibile

Mechanical motor, radio motor or M2Net.

- Iron headbox 51x57 mm
- Ladder and string tape
- Pelmet with magnet attachment
- Ceiling support
- For wall mounting use: cm 10 - 12 - 15 support (white, grey, black) cm 15 - 20 support (galvanized)

CURTAIN SIZE:

- mechanical motor VZ105: min 55 cm
- radio motor VZ118: min 66 cm
- M2Net VZ119: min 73 cm

Remote controls

Mechanical motors - VZ105

- 5096 Single wall fixing switch
- 5098 Switch
- 5158 R.F. receiver for 230 Vac motors

Radio motors - VZ118

- 5143 R.F. transmitter 1 system
- 5155 R.F. transmitter 15 systems
- 5148 Wall R.F. transmitter 1 system
- 5167 Wall fixing R.F. transmitter 15 systems
- 5168 Wall fixing timer transmitter R.F. 1 channel

M2Net - VZ119

- 5474B Touchscreen transmitter 1-4 systems white
- 5455B Touchscreen transmitter 15 systems white
- 5459B Touchscreen transmitter 99 systems white
- 5484B Extractable touchscreen transmitter 4 systems white

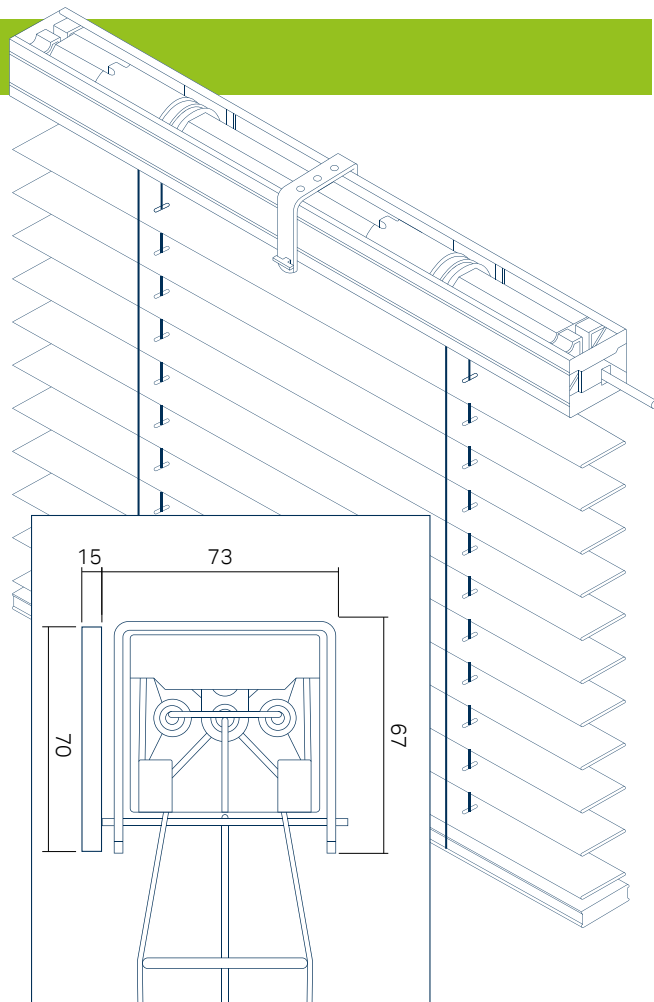

4. GUIDE GUIDED VERSION

VZ108 - Tende guidate / Guided blinds (fissaggio a pavimento / floor mounting)

VZ107 - Tende guidate / Guided blinds (fissaggio a parete / wall mounting)

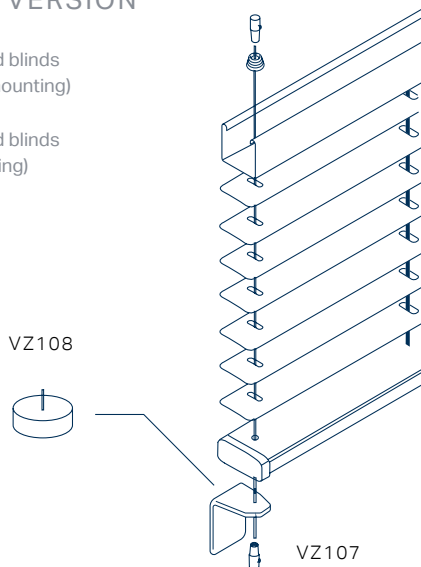

OPTIONAL (per / for 2. - 3.)

Supporto a parete per versione a motore e versione ad arganello
Wall support for motorized and crank versions

- 10 cm VZ10
- 12 cm VZ12
- 15 cm VZ15
- 15-20 cm VZ116

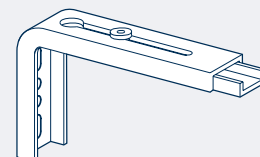



Cassonetto in legno 47x79 mm del colore delle lamelle. Meccanismo in 5 colori: nero, bianco, bronzo, girgio, avorio. Mantovana non disponibile.

Wooden headbox 47x79 mm, same color of the slats. Controls available in 5 colors: black, white, bronze, grey, ivory. The pelmet is not available.

Lamella di legno 50 mm Wood slat 50 mm

IMPACCHETTAMENTO / PACKING

| | Nastro 10-25 mm | Nastro 38 mm |
|------|-----------------|--------------|
| | L50 | L50 |
| 600 | 149 | 131 |
| 1000 | 179 | 172 |
| 1500 | 221 | 223 |
| 2000 | 269 | 276 |
| 2500 | 317 | 325 |
| 3000 | 365 | 376 |

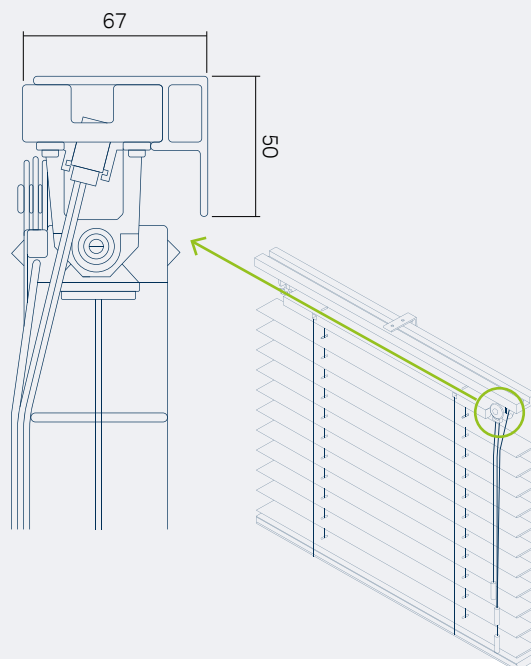

DIMENSIONI / DIMENSIONS

| | 25 mm | 35 mm | 50 mm | 70 mm |
|---------------------------------------|------------------|------------------|--------------------|--------------------|
| Superficie max Max surface | 3 m ² | 5 m ² | 7,5 m ² | 7,5 m ² |
| Misura lamella Slat dimension | 25 mm | 35 mm | 50 mm | 70 mm |
| Dimensioni larghezza Width dimensions | | | | |
| min: | 300 mm | 300 mm | 300 mm | 300 mm |
| max: | 2600 mm | 2600 mm | 3000 mm | 3000 mm |
| Dimensioni altezza Height dimensions | | | | |
| min: | 300 mm | 300 mm | 300 mm | 300 mm |
| max: | 2500 mm | 3000 mm | 3500 mm | 3500 mm |
| Cassonetto Headbox | L 37 X H 37 mm | L 37 X H 37 mm | L 57 X H 51 mm | L 57 X H 51 mm |
| Nastro Slat | 16 mm | 16 mm | 10 - 25 - 38 mm | 10 - 38 mm |
| Peso tenda massimo Max curtain weight | 10 kg | 10 kg | | |

N.B.: Ingombro (spessore lamella 3 mm) Folder heights (3 mm thickness slat)

IMPACCHETTAMENTO / PACKING

| 25 mm | | | 35 mm | | | 50 mm | | | | 70 mm | | |
|---------|--------|--------|---------|--------|--------|---------|--------|-----------|--------|---------|--------|-----------|
| H | B | C = 16 | H | B | C = 16 | H | B | C = 10-25 | C = 38 | H | B | C = 10-38 |
| 600 mm | 143 mm | 153 mm | 600 mm | 120 mm | 141 mm | 600 mm | 124 mm | 134 mm | 131 mm | 600 mm | 127 mm | 123 mm |
| 1000 mm | 205 mm | 224 mm | 1000 mm | 163 mm | 186 mm | 1000 mm | 159 mm | 173 mm | 172 mm | 1000 mm | 155 mm | 153 mm |
| 1500 mm | 283 mm | 312 mm | 1500 mm | 218 mm | 254 mm | 1500 mm | 202 mm | 221 mm | 223 mm | 1500 mm | 190 mm | 190 mm |
| 2000 mm | 360 mm | 400 mm | 2000 mm | 273 mm | 322 mm | 2000 mm | 245 mm | 269 mm | 276 mm | 2000 mm | 225 mm | 226 mm |
| 2500 mm | 438 mm | 488 mm | 2500 mm | 329 mm | 390 mm | 2500 mm | 288 mm | 317 mm | 325 mm | 2500 mm | 260 mm | 263 mm |
| | | | 3000 mm | 384 mm | 458 mm | 3000 mm | 331 mm | 365 mm | 376 mm | 3000 mm | 295 mm | 299 mm |
| | | | | | | 3500 mm | 374 mm | 413 mm | 427 mm | 3500 mm | 330 mm | 335 mm |

N.B.: H = Altezza Height B = Scaletta a filo Ladder string
C = Nastro Ladder tape (mm)

| LAMELLE SLATS | CASSONETTO UPPER BOX | COMANDO OPERATION | ORIENTAMENTO ADJUSTMENT | MANTOVANA PELMET | SUPPORTI A CHIAVETTA SWIVEL BRACHETS |
|---------------|----------------------|---------------------------|----------------------------|--|--------------------------------------|
| 25 mm | L 37 x H 37 mm | corda a destra right cord | corda a sinistra left cord | frontale + laterali frontal + laterals | parete-soffitto wall-ceiling support |
| 35 mm | L 37 x H 37 mm | corda a destra right cord | corda a sinistra left cord | frontale + laterali frontal + laterals | parete-soffitto wall-ceiling support |
| 50 mm | L 57 x H 51 mm | corda a destra right cord | corda a sinistra left cord | frontale + laterali frontal + laterals | parete-soffitto wall-ceiling support |
| 70 mm | L 57 x H 51 mm | corda a destra right cord | corda a sinistra left cord | frontale + laterali frontal + laterals | parete-soffitto wall-ceiling support |

N.B.: Sotto i 50 cm di larghezza NON è possibile unificare i comandi Under 50 cm width it is NOT possible to unify the controls

MANTOVANA / PELMET



Ingombro massimo = larghezza cassonetto + 30 mm
Max overall dimension = headbox width + 30 mm

Dimensioni mantovana = H 70 mm, spessore 10 mm
Pelmet dimensions = H 70 mm, thickness 10 mm

Cassonetto Lama 50/70 = H 70 mm, spessore 10 mm
Lama headbox 50/70 = H 70 mm, thickness 10 mm

Cassonetto Lama 25/35 = H 50 mm, spessore 10 mm
Lama headbox 25/35 = H 50 mm, thickness 10 mm

DESCRIZIONE FORMA / SHAPE DESCRIPTION

| | |
|--|--|
| | STANDARD - Mantovana frontale e a entrambi i lati Cover front and both sides of the rail |
| | Diritta - Mantovana frontale Cover only front of the rail |
| | Mantovana frontale e da un lato (SX) Cover front and left side of the rail |
| | Mantovana frontale e da un lato (DX) Cover front and right side of the rail |
| | Mantovana sui 4 lati (prezzo extra) Cover 4 sides of the rail (extra cost) |
| | Mantovana sui 2 lati principali (prezzo extra) Cover front and back of the rail (extra cost) |

FORME SPECIALI / SPECIAL SHAPES



APERTA OPEN

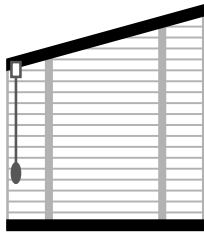

A

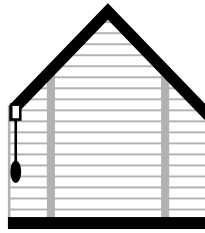

B

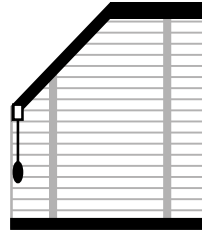

C

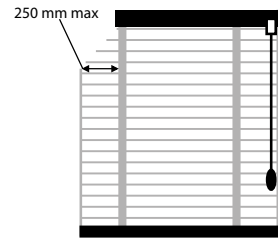

D

CHIUSA CLOSED

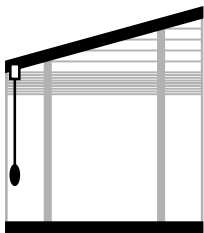

A

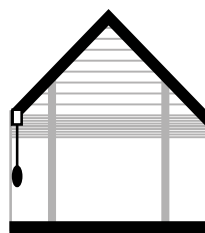

B

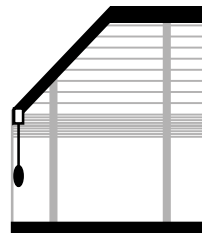

C

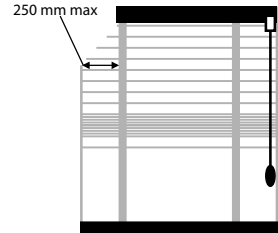

D

Solo con azionamento a corda. Finitura con scaletta filo.

Solo con modello CLASSICO da 25 mm, 35 mm, 50 mm e 70 mm. Altri modelli su richiesta. Le tende con forme speciali si impacchettano solo fino all'inizio dell'inclinazione. Il modello della mantovana è liscio e la larghezza e l'altezza saranno in proporzione alla sagoma della tenda. Il numero delle corde e la distanza tra le stesse dipenderà dalla sagoma della tenda e della sua inclinazione.

Manual operation only. ladder string only.

CLASSICO ange in 25 mm, 35 mm, 50mm and 70 mm slat only. Other models please ask. Shaped blinds will only rise up to the beginning of the inclination. The valance will be flat and the height and width adapted to the shape. The number of ladders and distance between them will not be symmetric as they will adequate to the shape of the blind and inclination grade.

COLORI SU RICHIESTA / ON DEMAND COLOUR

È possibile produrre qualsiasi colore speciale da un campione RAL o NCS. Per altri colori speciali abbiamo bisogno di ricevere un campione fisico da riprodurre.

It is possible to produce any special color from a RAL or NCS swatch. For other special colours we need to receive a physical sample to reproduce.



Z601/2
vers. 05/2026



mottura.com