

QuickFix solution
Ref. 1426+1436

MOTTURA

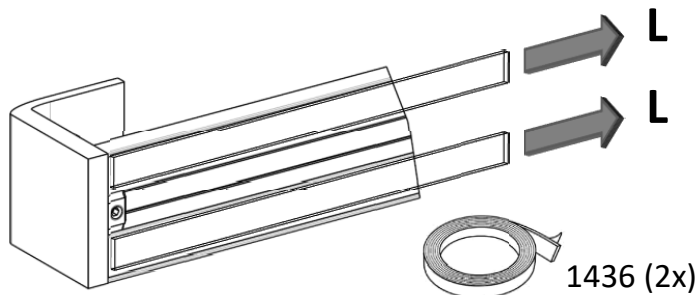
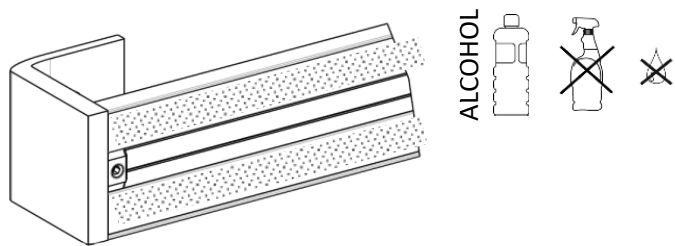
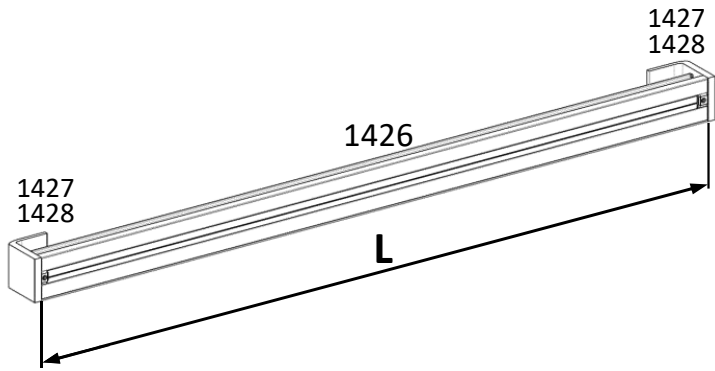

Z1426 - Istruzioni QuickFix 1426_1436

QuickFix solution
Ref. 1426+1436

MOTTURA

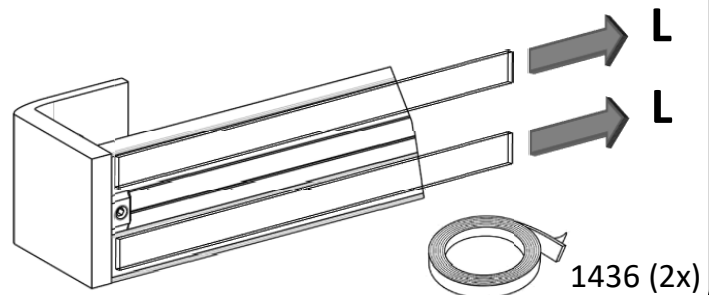
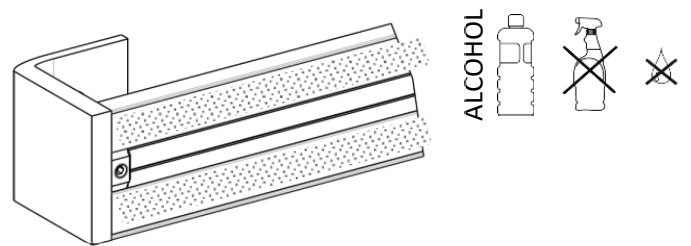
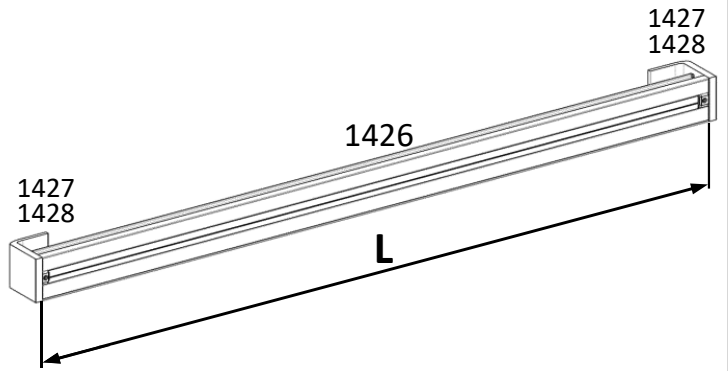

Z1426 - Istruzioni QuickFix 1426_1436

QuickFix solution
Ref. 1426+1436

MOTTURA

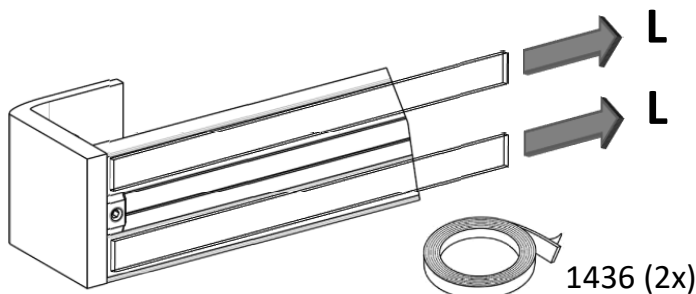
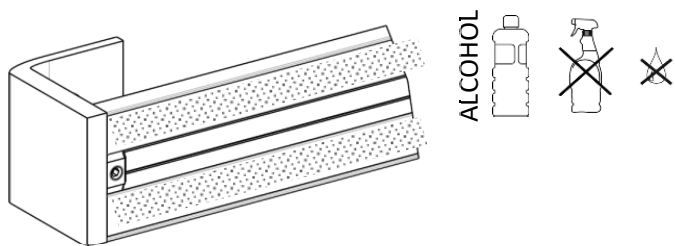
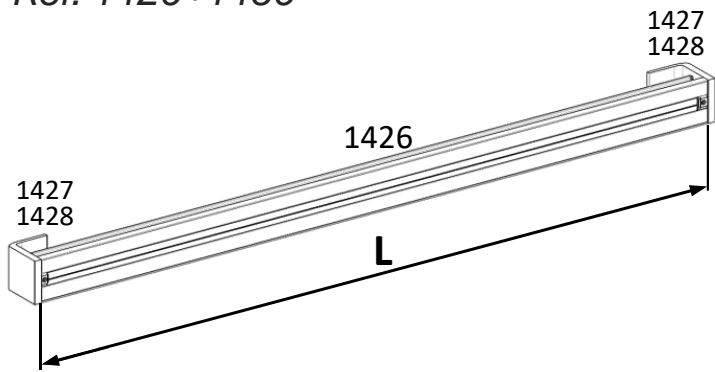

Z1426 - Istruzioni QuickFix 1426_1436

QuickFix solution
Ref. 1426+1436

MOTTURA

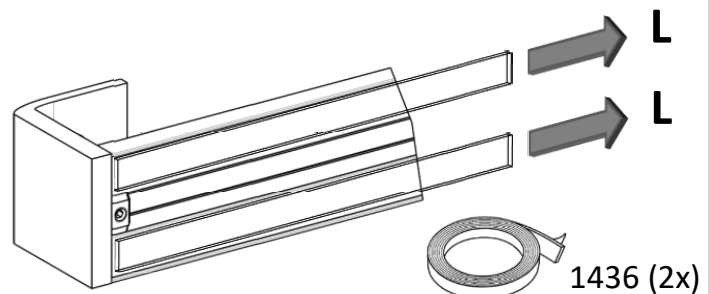
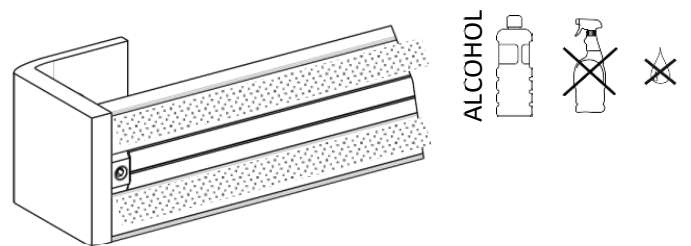
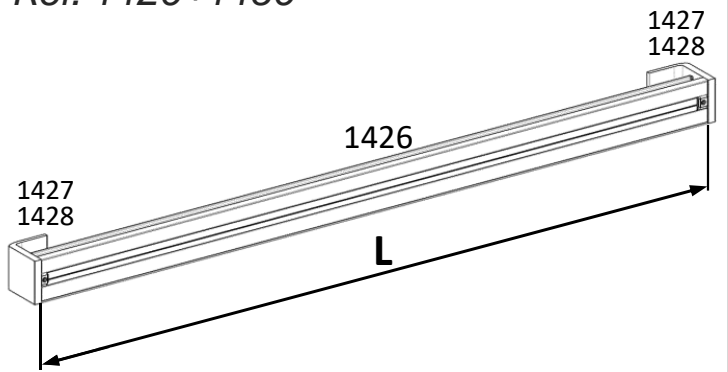

Z1426 - Istruzioni QuickFix 1426_1436

QuickFix solution **MOTTURA**

Ref. 1426+1436

1. Pulizia della superficie / Surface cleaning

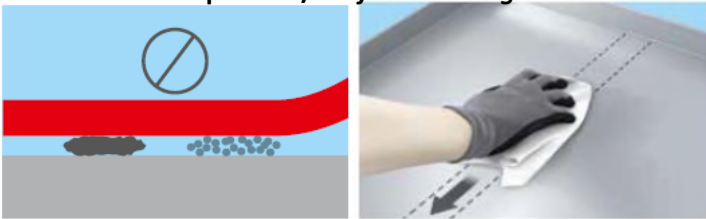

- Tesa® 60040 Industry Cleaner
- Alcohol
- Acetone

2. Applicazione / Application

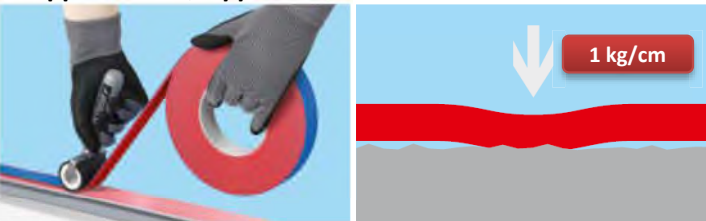

Dopo aver posizionato correttamente le parti, raccomandiamo l'applicazione di una pressione di 1 kg/cm su tutta la superficie dei component assemblati (usare il pollice o un rullo pressore).

After the final position is reached and both parts are mounted together, we recommend a uniform pressure of 1kg/cm over the complete area of the mounted components (use your thumb or a pressure roller).

3. Temperatura di posa / Processing temperature

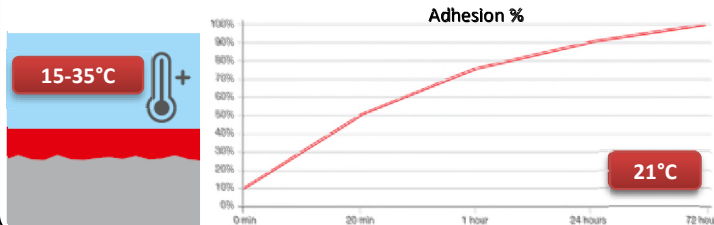

Z1426 – Istruzioni QuickFix 1426_1436

QuickFix solution **MOTTURA**

Ref. 1426+1436

1. Pulizia della superficie / Surface cleaning

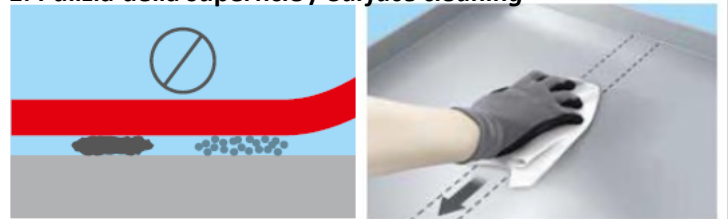

- Tesa® 60040 Industry Cleaner
- Alcohol
- Acetone

2. Applicazione / Application

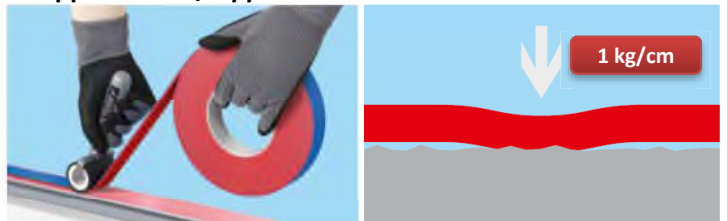

Dopo aver posizionato correttamente le parti, raccomandiamo l'applicazione di una pressione di 1 kg/cm su tutta la superficie dei component assemblati (usare il pollice o un rullo pressore).

After the final position is reached and both parts are mounted together, we recommend a uniform pressure of 1kg/cm over the complete area of the mounted components (use your thumb or a pressure roller).

3. Temperatura di posa / Processing temperature

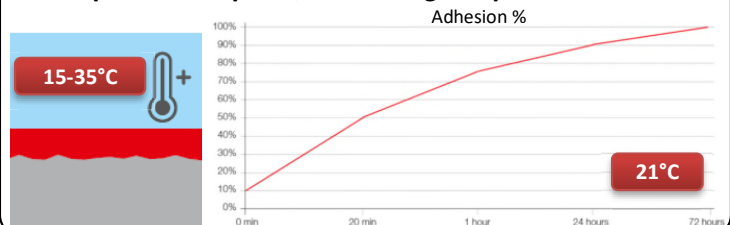

Z1426 – Istruzioni QuickFix 1426_1436

QuickFix solution **MOTTURA**

Ref. 1426+1436

1. Pulizia della superficie / Surface cleaning

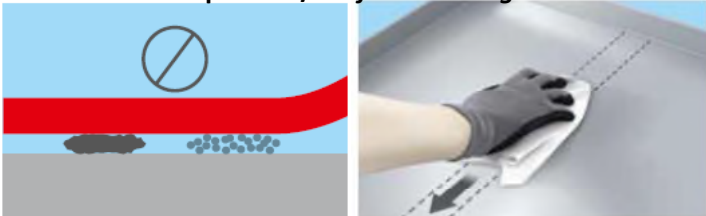

- Tesa® 60040 Industry Cleaner
- Alcohol
- Acetone

2. Applicazione / Application

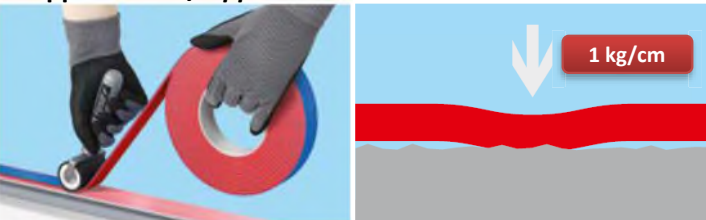

Dopo aver posizionato correttamente le parti, raccomandiamo l'applicazione di una pressione di 1 kg/cm su tutta la superficie dei component assemblati (usare il pollice o un rullo pressore).

After the final position is reached and both parts are mounted together, we recommend a uniform pressure of 1kg/cm over the complete area of the mounted components (use your thumb or a pressure roller).

3. Temperatura di posa / Processing temperature

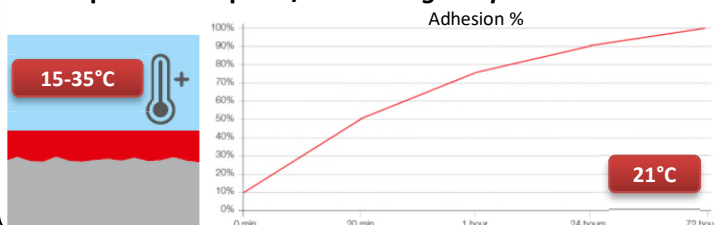

Z1426 – Istruzioni QuickFix 1426_1436

QuickFix solution **MOTTURA**

Ref. 1426+1436

1. Pulizia della superficie / Surface cleaning

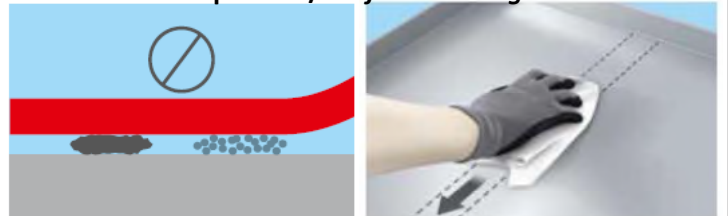

- Tesa® 60040 Industry Cleaner
- Alcohol
- Acetone

2. Applicazione / Application

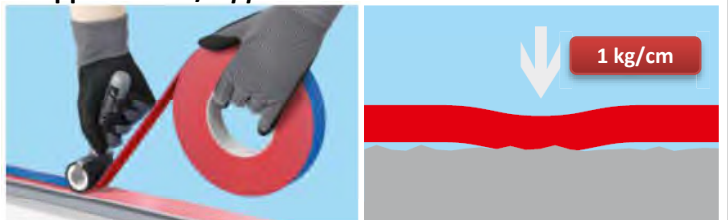

Dopo aver posizionato correttamente le parti, raccomandiamo l'applicazione di una pressione di 1 kg/cm su tutta la superficie dei component assemblati (usare il pollice o un rullo pressore).

After the final position is reached and both parts are mounted together, we recommend a uniform pressure of 1kg/cm over the complete area of the mounted components (use your thumb or a pressure roller).

3. Temperatura di posa / Processing temperature

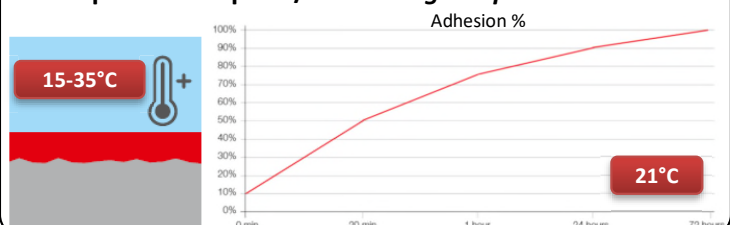

Z1426 – Istruzioni QuickFix 1426_1436