



TENDE VERTICALI

VERTICAL BLINDS

MOTTURA

Dual e Mono



DUAL 3359



MONO 3371/2



MONO 3371/3

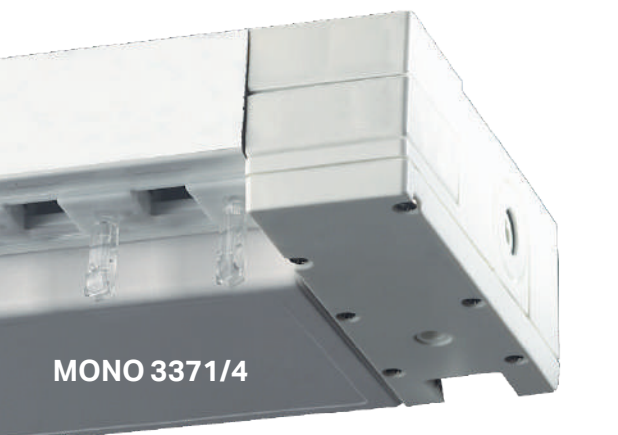

MONO 3371/4

IL SISTEMA PER TENDE A BANDE VERTICALI

Il sistema a bande verticali è un prodotto molto versatile che si presta a numerose applicazioni sia in ambienti domestici che in ambienti professionali. Si tratta di una soluzione di impatto estetico originale che è adatta alle più diverse esigenze architettoniche.

La larghezza dei teli che il sistema adotta di serie sono 89 mm (3,5 inches) e 127 mm (5,0 inches) ma è possibile realizzare teli di diversa larghezza.

Le tende a bande verticali rappresentano una soluzione ottimale per modulare la luminosità e creare i più differenti effetti luminosi e, inoltre, contribuiscono a ridurre il problema del calore all'interno dell'ambiente.

THE VERTICAL BLINDS SYSTEM

The vertical blinds system is a very versatile product that lends itself to many applications in both domestic and professional environments. The vertical blinds system is a solution of the original aesthetic impact that is suitable for different architectural requirements.

The width of the slats that the system is fitted as standard are 89 mm (3.5 inches) and 127 mm (5 inches) but it is possible to realize slats of different width.

The vertical blinds systems also represent an optimal solution to modulate the brightness and to create many different lighting effects and also help to reduce the problem of heat in the environment.

UNA GAMMA COMPLETA

Performance e qualità, da sempre, sono le priorità nelle tende tecniche Mottura. La gamma è: **Dual 359** - sistema a doppio comando per orientamento e traslazione dei teli. **Mono 3371/2** - sistema monocomando curvabile con azionamento a catenella. **Mono 3371/3** - sistema monocomando curvabile con azionamento ad arganello. **Mono 3371/4** - sistema monocomando curvabile con azionamento a motore.

A FULL RANGE

Performance and quality, as always, the priorities in Mottura technological systems. The offered range is: Dual 359 - Chain/cord operating system for slats tilting and opening/closing. Mono 3371/2 - bendable monocontrol chain operating system. Mono 3371/3 - bendable monocontrol winch operating system. Mono 3371/4 - bendable monocontrol electrical operating system.

SOLUZIONI

Dual e Mono possono essere realizzate in numerose configurazioni diritte, inclinate o curve allo scopo di adattarsi alle più diverse soluzioni architettoniche.

APPLICATIONS

Dual Mono and can be produced in numerous configurations, straight, inclined or curved in order to adapt to different architectural solutions.

HOME AUTOMATION

M2Net è la soluzione sviluppata da Mottura per la gestione dell'Home Automation. Mono 3371/4 è un sistema M2Net compatibile. L'elettronica di gestione è stata sviluppata per l'impiego del sistema 3371/4 in reti digitali wireless o by wire con scambio bidirezionale, tra attuatore e dispositivo di comando.

HOME AUTOMATION

M2Net is the solution developed by Mottura for Home Automation Control. Mono 3371/4 is a system M2Net compatible. The control electronics have been developed to use Mono in wireless digital network or by wire with bi-directional exchange, between actuator and control device. Mono systems can be connected by a bus digital line operated by wire or PC.

Plus

INGOMBRO RIDOTTO

La ridotta sezione dei vagonetti di Dual 359 permette un minore ingombro laterale a tenda raccolta e gli spaziatori in acciaio permettono una sovrapposizione dei teli geometricamente perfetta. Inoltre, con un solo movimento, tutti i teli di Dual 359 possono essere sganciati dall'arresto carrelli ed essere traslati da un lato per consentire una più agevole pulizia dei vetri.

1

MINIMUM OVERALL

The reduced section of the Dual 359 runners means less lateral overall with the blind gathered up and the inox steel spacers allows a geometrically perfect overlapping of the slats. Besides, with a single action, all the louvres can be unhooked from the carrier stop and can be traversed to one side to easily cleaning the windows.



VERSATILITÀ

Dual 359 è prevista per aperture della tenda centrali, laterali o simmetriche ed anche per applicazione in presenza di soffitti inclinati, quali mansarde ed architetture particolari.

2

VERSATILITY

Dual 359 allows central, lateral or symmetric opening of the slats and it is suitable for application in the presence of slanted ceilings, attics and particular architectures.



CURVABILITÀ

Mono è il sistema curvabile a 90° ed ad ampio raggio; da sempre la curvabilità è una delle caratteristiche prioritarie dei sistemi Mottura ed anche Mono risponde a questa esigenza.

3

BENDED SYSTEMS

Mono is 90° or large radius bendable system. As always, the ability to be curved is one of the priority characteristics of Mottura systems and Mono respond to this need too.

PRODOTTI SICURI

I sistemi Dual e Mono sono sistemi conformi alla norma EN 13120 che tutela la sicurezza dei bambini e quindi sono prodotti indicati anche per l'uso domestico.

Mono 3371/3 con azionamento ad arganello e Mono 3371/4 con azionamento a motore, a questo scopo, sono soluzioni ottimali.

4

CHILDREN SAFETY SYSTEMS

Dual and Mono are systems according to EN 13120 which ensures the safety of children and therefore the products are also suitable for home use.

Mono 3371/3, winch operating, and Mono 3371/4, the motorized version, are optimal solutions.





M2Net. L'evoluzione tecnologica dell'Home Automation secondo Mottura.

Mono 3371/4 è azionato da un attuatore digitale alimentato a 90-250 Vac e frequenza 50-60Hz. L'attuatore digitale è caratterizzato da un motoriduttore a 24Vdc con encoder integrato controllato da una scheda elettronica dotata di alimentatore switching, processore di gestione e ricevitore radio bidirezionale 868/915 Mhz integrato. Il suo software di gestione permette il controllo della movimentazione e della velocità di traslazione.

Mono 3371/4 adotta il protocollo di comunicazione M2Net che permette al sistema di dialogare in ambiente wireless Mottura.

Il protocollo bidirezionale M2Net è il fulcro della comunicazione tra i sistemi Mottura e l'utilizzatore, garantendo l'avvenuta esecuzione del comando in remoto.

Mono 3371/4 è un prodotto a basso consumo. Il suo motore digitale garantisce un risparmio energetico del 70% rispetto ai sistemi 230 Vac.

M2Net. Technological Evolution of Home Automation by Mottura.

Mono 3371/4 is driven by a digital actuator supply with tension 90-250 Vac and frequency of 50-60Hz.

The digital actuator is characterized by a gearmotor 24 Vdc with integrated encoder controlled by an electronic mainboard equipped with a switching power supply, control processors and two-way radio receiver 868/915 Mhz integrated.

Its software allows control of handling and speed.

Mono 3371/4 adopts M2Net communication protocol that allows the system to communicate in Mottura wireless environment.

The two way protocol M2Net is the hub of communications between Mottura systems and the customer, ensuring the successful execution of the command remotely.



Mono 3371/4 is an energy saving device. The motor is able to save up to 70% of energy comparing to the 230 Vac systems.



Performances



Kg	1,5 m	2,5 m	3,5 m	4 m	5 m	6 m
----	-------	-------	-------	-----	-----	-----

DUAL 359 - 127 mm

	5 kg	6,5 kg	8,5 kg	10 kg	12 kg	14 kg
	5 kg	6,5 kg	8,5 kg	10 kg	12 kg	14 kg
	2,5 kg	3,2 kg	5 kg	6 kg	7 kg	-

Kg	1,5 m	2,5 m	3,5 m	4 m	5 m	6 m
----	-------	-------	-------	-----	-----	-----

DUAL 359 - 89 mm

	5 kg	6,5 kg	8,5 kg	10 kg	-	-
	5 kg	6,5 kg	8,5 kg	10 kg	-	-
	2,5 kg	3,2 kg	5 kg	6 kg	-	-







Kg	1,5 m	2,5 m	3,5 m	4 m	5 m	6 m
----	-------	-------	-------	-----	-----	-----

MONO 3371/2 - 127 mm









	2,5 kg	4 kg	6 kg	6,5 kg	-	-
	2,5 kg	4 kg	6 kg	6,5 kg	-	-
	2,5 kg	4 kg	6 kg	-	-	-
	2,5 kg	4 kg	6 kg	-	-	-
	2,5 kg	4 kg	6 kg	-	-	-
	2,5 kg	4 kg	6 kg	-	-	-
	2,5 kg	4 kg	6 kg	-	-	-

Kg	1,5 m	2,5 m	3,5 m	4 m	5 m	6 m
----	-------	-------	-------	-----	-----	-----









MONO 3371/2 - 89 mm

	2,5 kg	4 kg	-	-	-	-
	2,5 kg	4 kg	-	-	-	-
	2,5 kg	4 kg	-	-	-	-
	2,5 kg	4 kg	-	-	-	-
	2,5 kg	4 kg	6 kg	-	-	-
	2,5 kg	4 kg	6 kg	-	-	-
	2,5 kg	4 kg	-	-	-	-







MONO 3371/3 - 127 mm

	2,5 kg	4 kg	6 kg	6,5 kg	8,5 kg	-
	2,5 kg	4 kg	6 kg	6,5 kg	8,5 kg	10 kg
	2,5 kg	4 kg	6 kg	6,5 kg	8,5 kg	-
	2,5 kg	4 kg	6 kg	6,5 kg	8,5 kg	10 kg
	2,5 kg	4 kg	6 kg	6,5 kg	8,5 kg	-
	2,5 kg	4 kg	6 kg	6,5 kg	8,5 kg	10 kg
	2,5 kg	4 kg	6 kg	6,5 kg	8,5 kg	-
	2,5 kg	4 kg	6 kg	6,5 kg	8,5 kg	10 kg







MONO 3371/3 - 89 mm

	2,5 kg	4 kg	6 kg	-	-	-
	2,5 kg	4 kg	6 kg	6,5 kg	8,5 kg	-
	2,5 kg	4 kg	6 kg	-	-	-
	2,5 kg	4 kg	6 kg	6,5 kg	-	-
	2,5 kg	4 kg	6 kg	-	-	-
	2,5 kg	4 kg	6 kg	6,5 kg	-	-
	2,5 kg	4 kg	6 kg	-	-	-
	2,5 kg	4 kg	6 kg	6,5 kg	-	-

MONO 3371/4 - 127 mm

	2,5 kg	4 kg	6 kg	6,5 kg	8,5 kg	-
	2,5 kg	4 kg	6 kg	6,5 kg	8,5 kg	10 kg
	2,5 kg	4 kg	6 kg	6,5 kg	8,5 kg	-
	2,5 kg	4 kg	6 kg	6,5 kg	8,5 kg	10 kg
	2,5 kg	4 kg	6 kg	6,5 kg	8,5 kg	-
	2,5 kg	4 kg	6 kg	6,5 kg	8,5 kg	10 kg
	2,5 kg	4 kg	6 kg	6,5 kg	8,5 kg	-
	2,5 kg	4 kg	6 kg	6,5 kg	8,5 kg	10 kg

MONO 3371/4 - 89 mm

	2,5 kg	4 kg	6 kg	-	-	-
	2,5 kg	4 kg	6 kg	6,5 kg	8,5 kg	-
	2,5 kg	4 kg	6 kg	-	-	-
	2,5 kg	4 kg	6 kg	6,5 kg	8,5 kg	-
	2,5 kg	4 kg	6 kg	-	-	-
	2,5 kg	4 kg	6 kg	6,5 kg	8,5 kg	-
	2,5 kg	4 kg	6 kg	-	-	-
	2,5 kg	4 kg	6 kg	6,5 kg	8,5 kg	-

Forme e soluzioni / Shapes and solutions

DUAL 3359

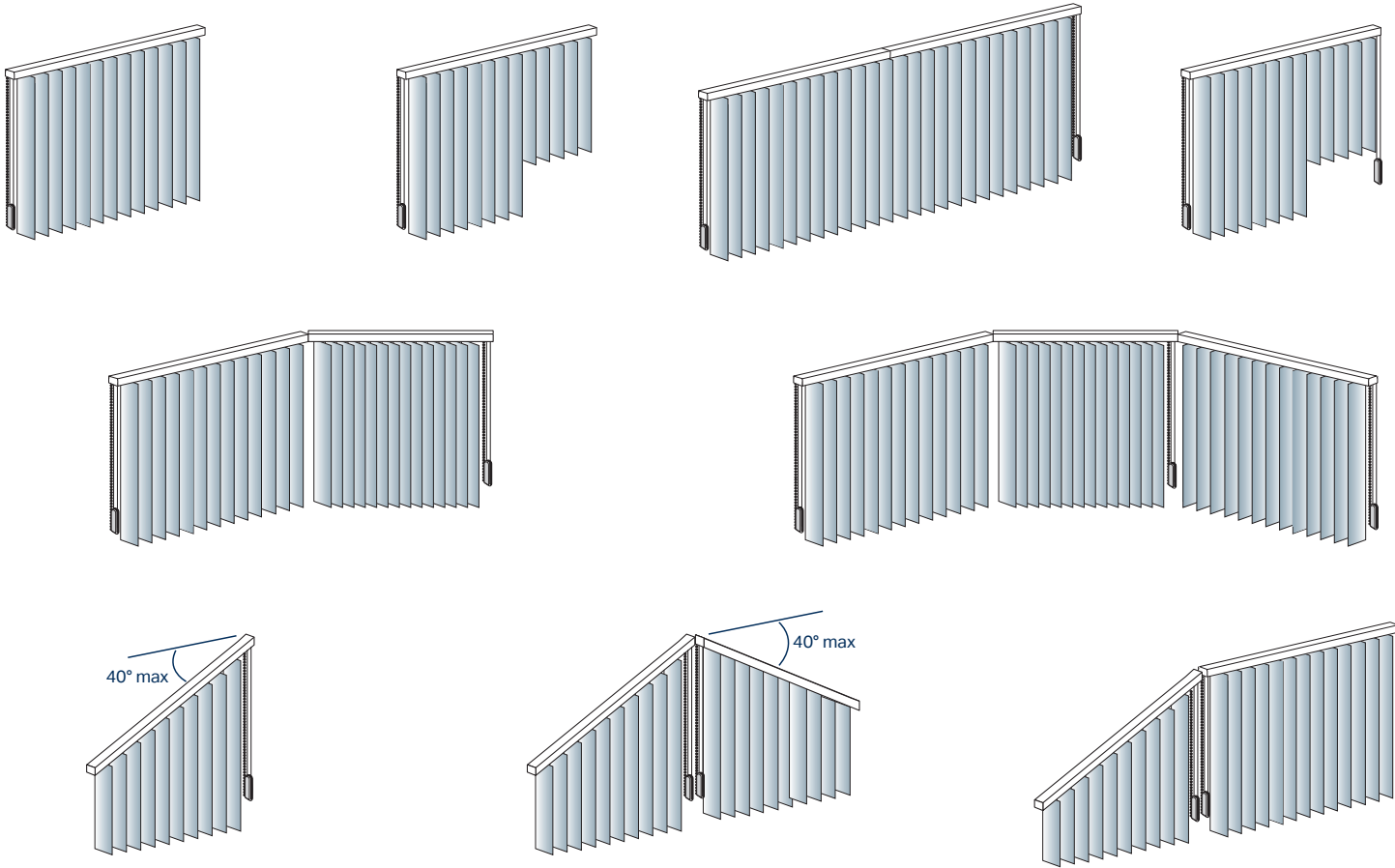

MONO 3371/ 2 - MONO 3371/ 3 - MONO 3371/ 4

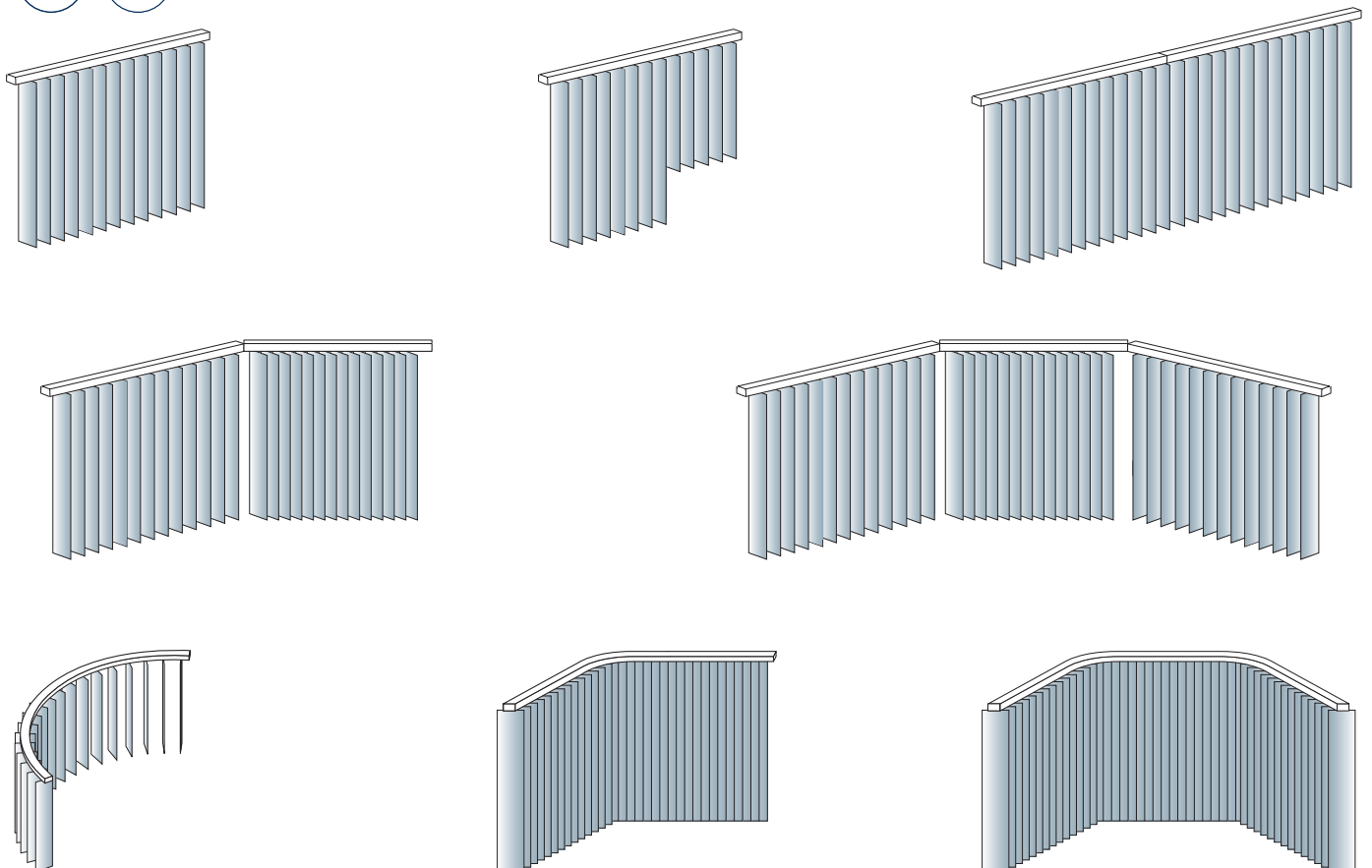

Aperture / Openings

DUAL 3359 - MONO 3371/2 - MONO 3371/3 - MONO 3371/4

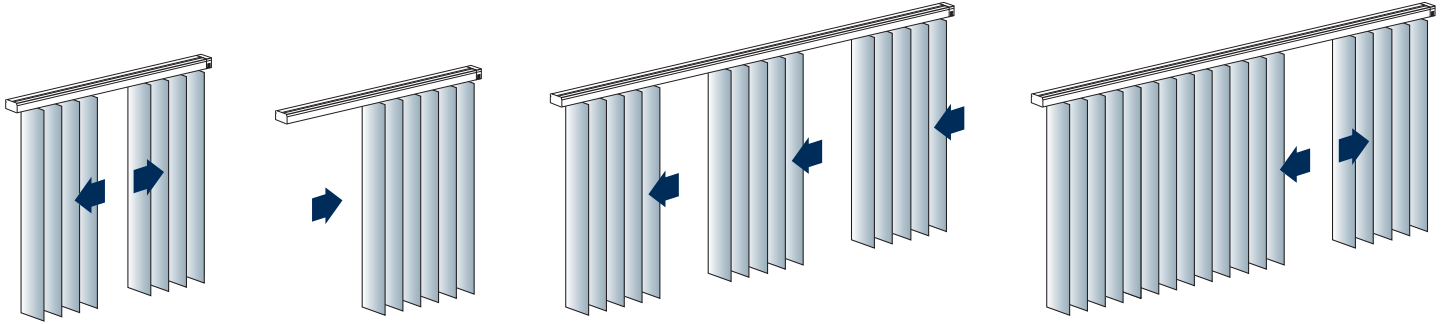

Installazioni / Installations

DUAL 3359

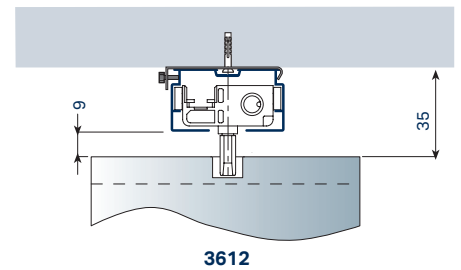
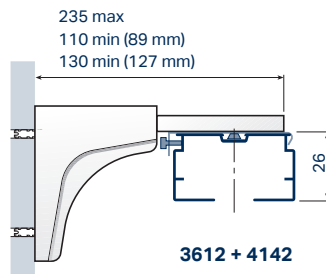
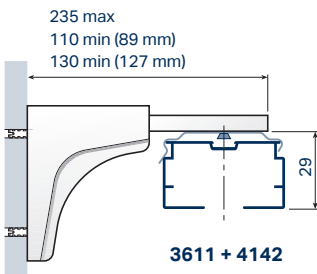
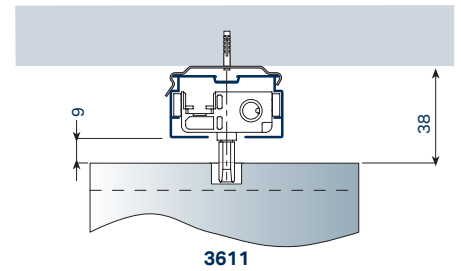
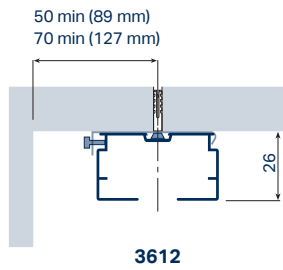
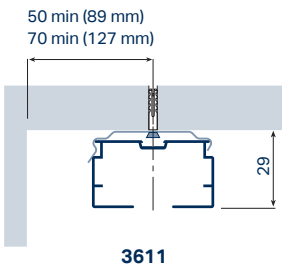

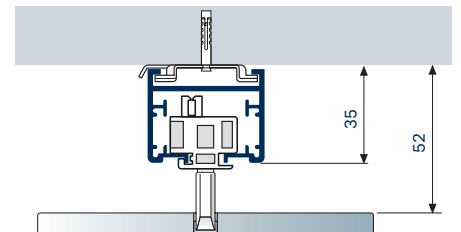
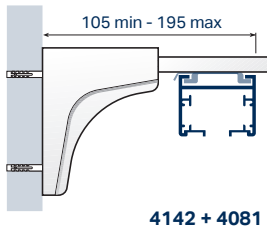
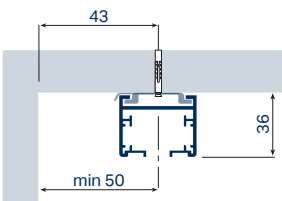

MONO 3371/2 - MONO 3371/3

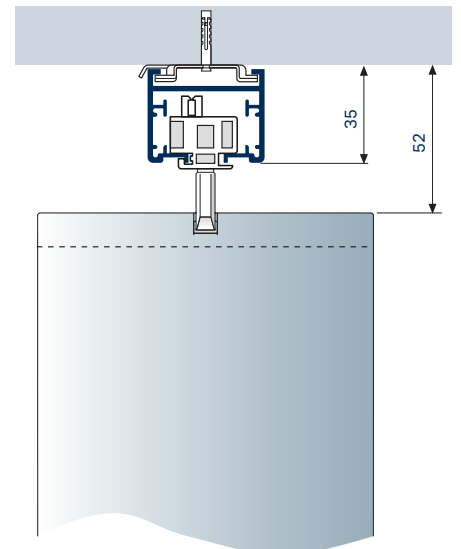
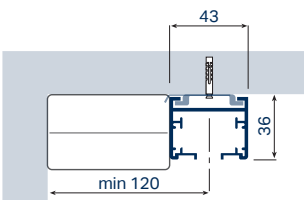

MONO 3371/4

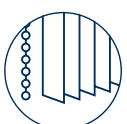

La gamma / The range

SISTEMA SYSTEM	AZIONAMENTO OPERATION	TESSUTI FABRICS			INSTALLAZIONE INSTALLATION	
		FILTRANTI FILTERING	ATTENUANTI DIM-OUT	OSCURANTI BLACK-OUT	SOFFITTO CEILING	PARETE WALL
DUAL 359		•	•	•	•	•
MONO 3371/2		•	•	•	•	•
MONO 3371/3		•	•	•	•	•
MONO 3371/4		•	•	•	•	•

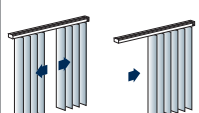
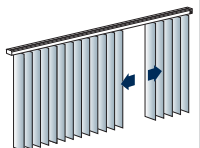
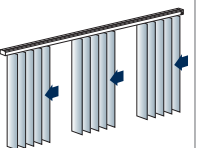
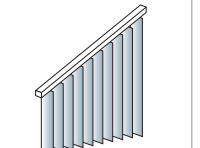
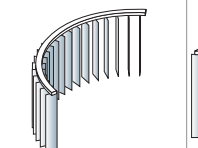
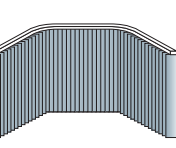
						
DUAL 359	•	•	•	•		
MONO 3371/2	•	•	•		•	•
MONO 3371/3	•	•	•		•	•
MONO 3371/4	•	•	•		•	•