

Modulo 105

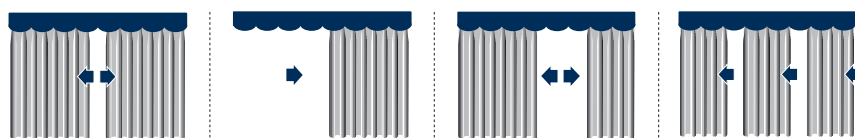

1.1.97





CARATTERISTICHE TECNICHE - SPECIFICATIONS CARACTERÍSTICAS - CARACTERÍSTICAS - CARACTÉRISTIQUES EIGENSCHAFTEN - KARAKTERISTIEKEN - ХАРАКТЕРИСТИКИ

- Profilo in lega d'alluminio estrusa 6060 T6 UNI 8278
 - Larghezza 48 mm - Altezza 10,3 mm
 - Canale di scorrimento: 6 mm
 - Finitura superficiale: verniciatura poliestere bianco RAL 9016 lucido altri colori a richiesta
 - Carrucole in termoplastico antiurto con ruote su perni in acciaio
 - Accessori in acetilica autolubrificante
- 6060 T6 UNI 8278 extruded aluminium alloy track
 - Width 48 mm - Height 10.3 mm
 - Sliding channel: 6 mm
 - Surface finish: RAL 9016 white polyester paint polished available on request
 - Shockproof thermoplastic pulleys with wheels on steel journals
 - Self-lubricating acetylic accessories
- Perfil en aleación de aluminio extruido 6060 T6 UNI 8278
 - Anchura 48 mm - Altura 10,3 mm
 - Canal de deslizamiento: 6 mm
 - Acabado de la superficie: pintura poliéster blanca RAL 9016 brillante otros colores bajo petición
 - Polea en termoplástico endurecido con ruedas sobre ejes de acero
 - Accesorios de acetálico autolubrificante
- Perfil de liga de alumínio extrudido 6060 T6 UNI 8278
 - Largura 48 mm - Altura 10,3 mm
 - Calha de deslizamento: 6 mm
 - Acabamento superficial: tinta de poliéster branca RAL 9016 polido outras cores a pedido
 - Polias de material termoplástico anti-choque com rodas aplicadas em pernos de aço
 - Acessórios de resina acetálica autolubrificante
- Profil en alliage d'aluminium extrudé 6060 T6 UNI 8278
 - Largeur 48 mm - Hauteur 10,3 mm
 - Rail de coulissement: 6 mm
 - Finition superficielle: peinture polyester blanc RAL 9016 brillant autres couleurs sur demande
 - Poulies en matériau thermoplastique antichoc avec roues sur pivots en acier
 - Accessoires en résine d'acétal autolubrificante
- Profil aus extrudierter Alu-Legierung 6060 T6 UNI 8278
 - Breite 48 mm - Höhe 10,3 mm
 - Laufkanal: 6 mm
 - Oberflächen-Finish: Polyesterlackierung Weiß RAL 9016 poliert andere Farben auf Anfrage
 - Umlenkungen aus stoßfestem Thermoplast mit Rollen auf Stahlbolzen
 - Zubehör aus selbstschmierendem Acetal
- 6060 T6 UNI 8278 geëxtrudeerd aluminium profiel
 - Breedte 48 mm - hoogte 10,3 mm
 - Kanaalbreedte 6 mm
 - Afwerking: RAL 9016 wit polyester lak gepolijst andere kleuren op aanvraag
 - Schokbestendige thermoplastische poelies met wielen op metalen as
- Профиль из экструдированного алюминиевого сплава 6060 T6 UNI 8278
 - Ширина 48 мм - Высота 10,3 мм
 - Желоб: 6 мм
 - Отделка поверхности: полиэфирная окраска в белый цвет RAL 9016 полированный другие цвета — по запросу
 - Шкивы из противоударного термопласта с колесами на стальных осях
 - Принадлежности из самосмазывающейся ацеталовой пластмассы

UTILIZZO

USE
USO
USO
UTILISATION
ANWENDUNG
GEBRUIK
ИСПОЛЬЗОВАНИЕ

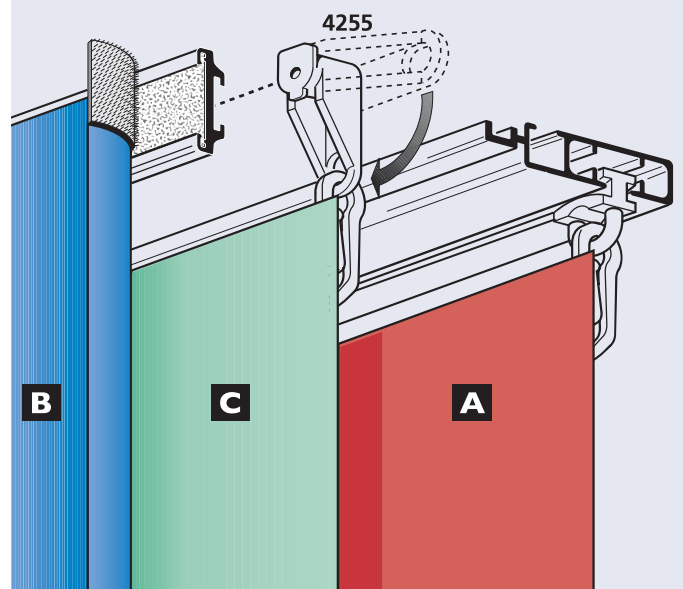
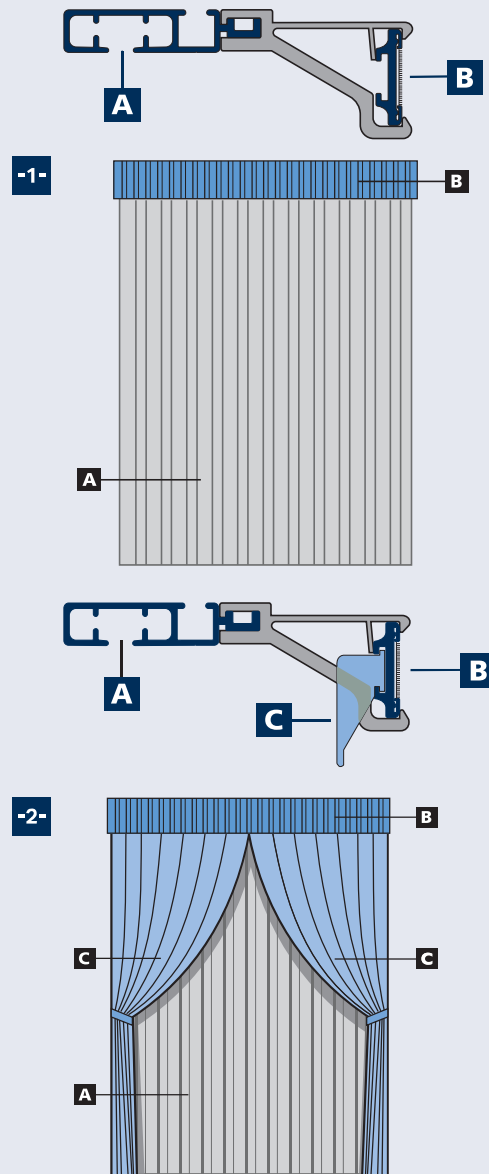



1.1.100

Modulo 105

INSTALLAZIONE

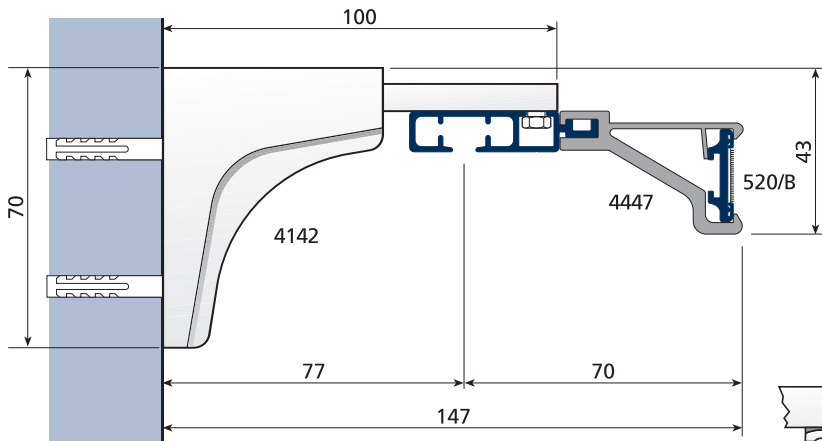

INSTALLATION
 INSTALACIÓN
 INSTALAÇÃO
 INSTALLATION
 INSTALLATION
 INSTALLATIE
 УСТАНОВКА

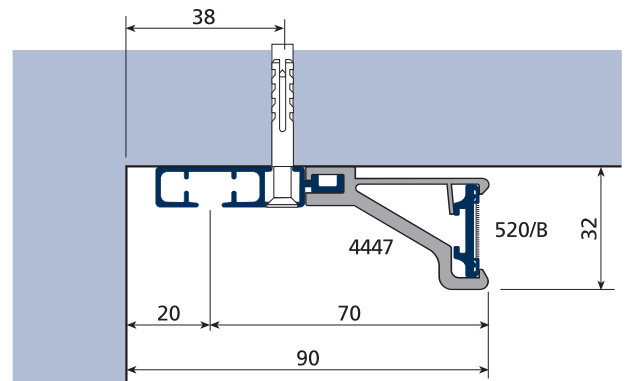
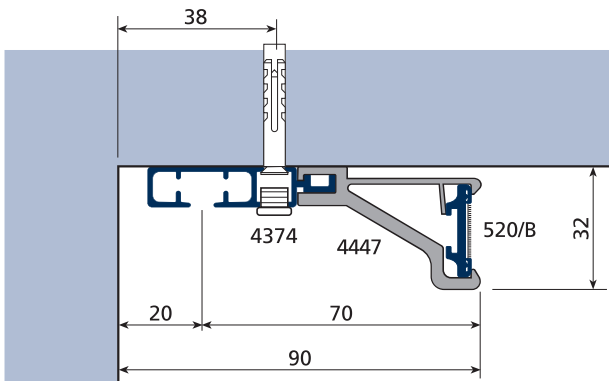
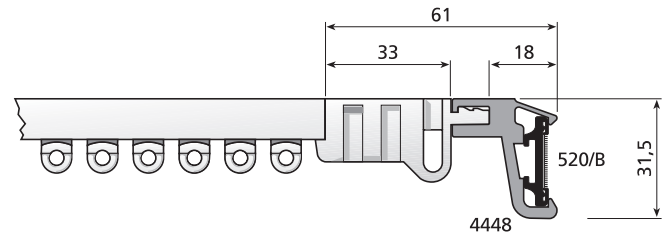

ANGOLI

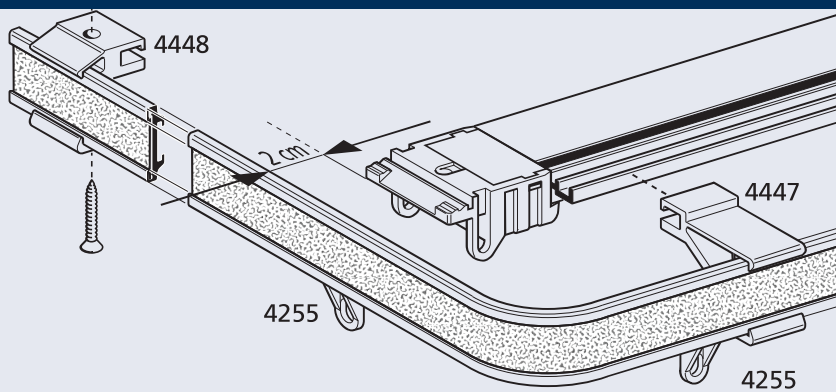

ANGLES
 ANGULOS
 ÂNGULOS
 ANGLÉS
 WINKEL
 HOEKEN
 УГОЛ

CONFEZIONI CONSIGLIATE

A RAPPORTO DI ARRICCIAIURA
 THE SPACE BETWEEN THE PLEATS
 RAPPORT DE FRUNCIDO
 RELAÇÃO DE FRANZIDO
 INDIQUE LA DISTANCE ENTRE PLUS
 GIBT DEN RAFFRAPPORT AN
 GEEFT DE AFSTAND TUSSEN DE PLOOIEN AAN
 ВИД ДРАПИРОВКИ

B NASTRO - TAPE
 CINTA - FITA
 GALON - BAND
 ЛИНТ - ЛЕХТА

	A	B
	1:2	art. 768 - h 30 mm
	1:2	art. 768 - h 30 mm

SUGGESTED STYLES OF CURTAINS
 TIPOS DE CONFECCIÓN
 TIPOS DE CORTINAS ACONSELHADOS
 CONFECTION CONSEILLÉE
 EMPFOHLENE VORHANGBÄNDER
 AANBEVOLEN CONFECTIE
 МОДЕЛЬ

