



tende & scorritenda

Safety devices

Istruzioni di montaggio
Assembly Instructions



Mottura S.p.A.

Via XXV Luglio, 1 - 10090 - San Giusto Canavese (To) - Italia

Tel. (0039) 0124.49.49.49 - Fax (0039) 0124.49.49.18

Internet: www.mottura.com - E-mail: mottura@mottura.com

INDEX

Child safety devices guidelines	1
Warning label.....	3
Safety chain joint (art.1301).....	4
The lenght of the chain must comply with the rules of section “Child safety devices guidelines”	4
Safety chain guide (art.1303)	7
Fixed retaining device (art.3636)	10
Safety chain tensioner (art.1304)	13
Safety cord joint (art.1302) and accumulation device (art.8058).....	16
Rear cord breakaway system (art.1305-1306).....	22

Child safety devices guidelines



According to the new issue of the standard about safety requirements for internal blinds EN13120 and related (EN16433-EN16434), it's compulsory to produce and commercialize safe blinds that fulfil the requirements of these standards.

It's important to observe these instructions to prevent damage to property or persons.

All devices produced by Mottura S.p.A. are tested and approved according to the indications of the standard EN 16434:2013 Internal blinds – Protection from strangulation Hazards – Requirements and test methods for Safety devices.

All the configurations represented in this manual are tested and approved according to the indications of the standard EN 13120:2009/A1:2014 Internal blinds – Performance requirements including safety and EN 16433:2013 Internal blinds – Protection from strangulation hazards – Test method

Below are indicated the rules to define the length of cords and chains based on the height of the blind and the height of installation (when specified).







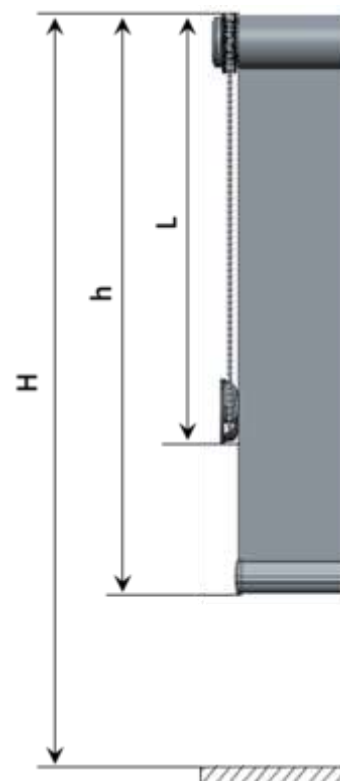







All safety devices listed in this manual are equipped with safety warning (Z247/2), with instruction manual for a correct assembly and use and with bag and strap for attach all parts to the system as required by the standard.

Length calculation for operation cord/chain

Art.	<i>h</i>	<i>H</i>	<i>L</i>
1301	/	OK	H – 60cm
		?	2/3 h
1303	h < 2,5m	OK	H – 150cm
		?	Max 100cm
3636	h > 2,5m	OK	H – 150cm
1304		?	h – 150cm



Summary table use devices

	1301  3679	1302 	1303 	1304 	1305-6 	3636 	8058 
						✓	
	✓	✓			✓	✓	✓
						✓	
				✓			
	✓		✓			✓	
	✓		✓			✓	
	✓	✓				✓	✓
	✓	✓				✓	✓

Warning label

The warning label to attach at the system is marked as shown below:

ATTENTION

- young children have been strangled by loops in pull-cords, chains and tapes, and cords that operate the product.
- to avoid strangulation and entanglement, keep cords out of the reach of young children. cords may become wrapped around a child's neck.
- move beds, cots and furniture away from window covering cords.
- do not tie cords together. make sure cords do not twist and create a loop.

The color of the label must be orange.

The text must be translated in all the languages of the states in the European community where the blind is commercialized.





Safety chain joint (art.1301 – art.3679)

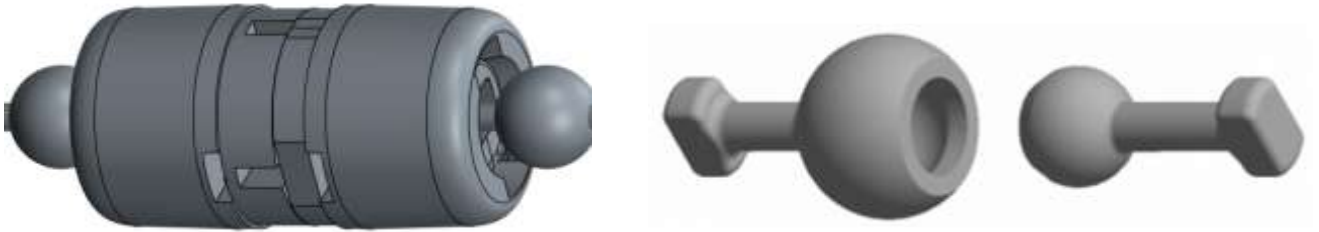

This device can be used in the following systems:

- Rotary 444/2 – 445/2
- Softbox 435/2 – 440/2
- Qbox 453 (4225)
- Sidewinder 8220 – 8230 – 8240
- Rollbox 245 – 265 (7230-7240) – 260
- Pli 353/2 (8034)
- Venù 16/X (B) – 25/X (B)

The length of the chain must comply with the rules of section “Child safety devices guidelines”

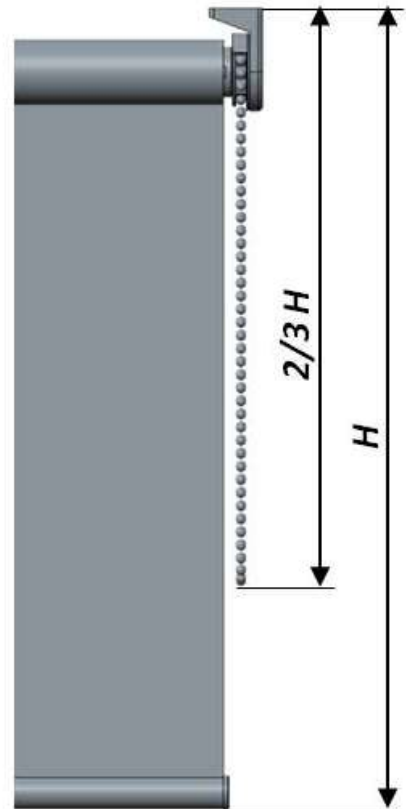
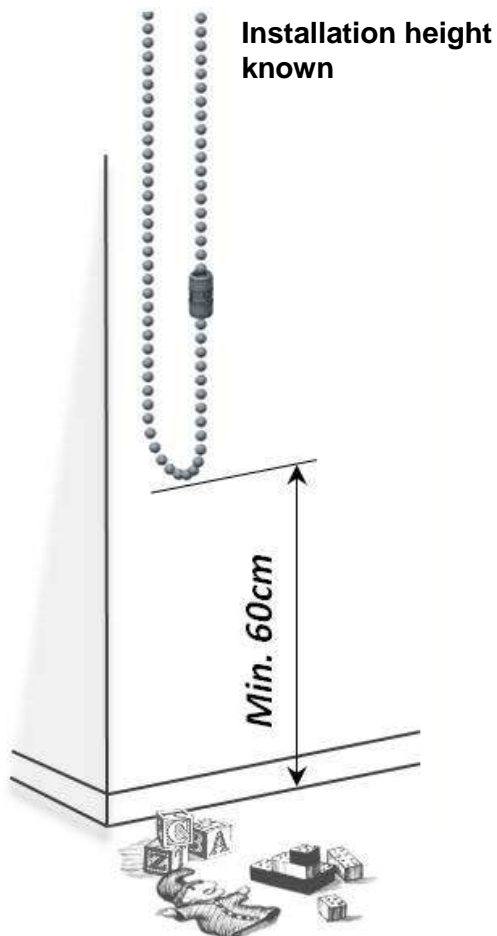

Installation height not known

Assembly device 1301

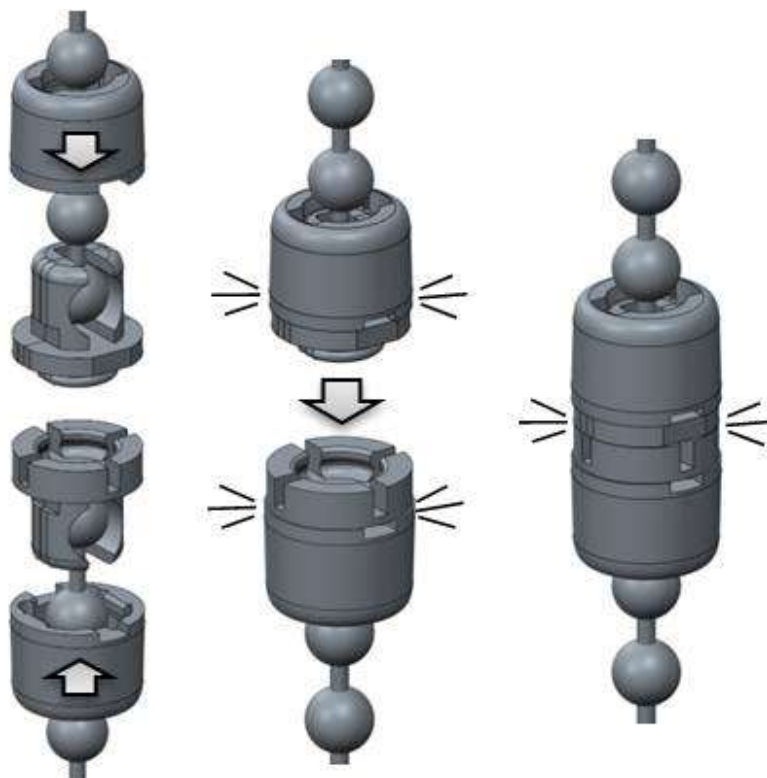
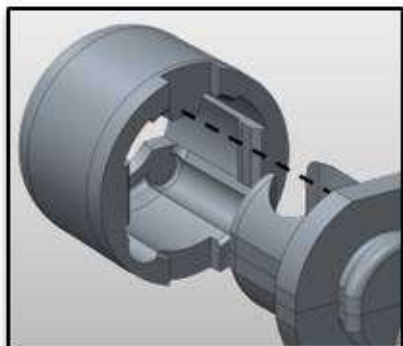

System assembly

Insert instruction into the bag and link bag and warning label to the chain with the provided strap.



Insert the system in the plastic bag with the warning instructions printed.

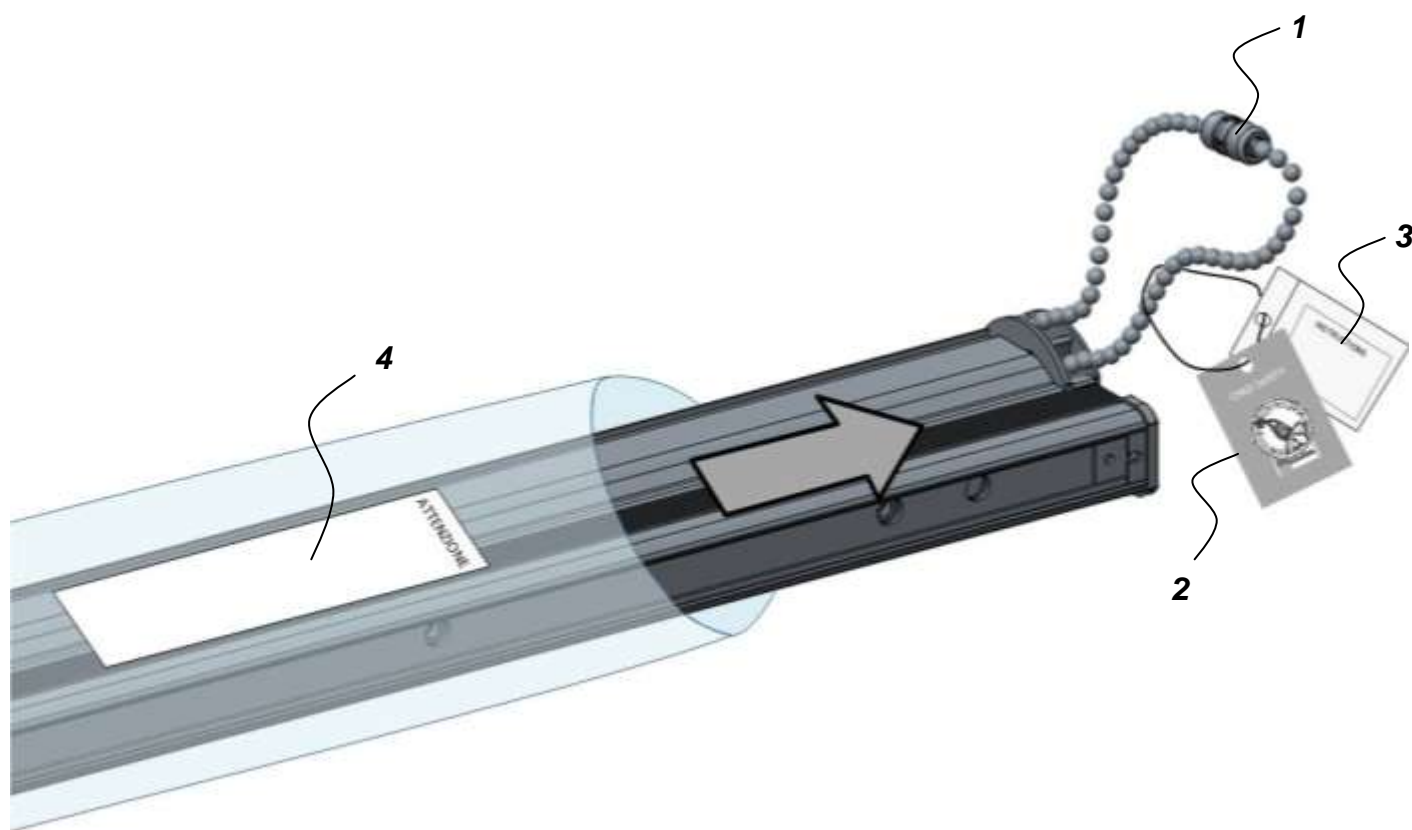

- 1 – 1301 – Breakaway device for chain
- 2 – 1307 – Warning label
- 3 – 1308/1 – Assembly instructions
- 4 – 1061/64/65/66 – Plastic bag with warning instructions



Safety chain guide (art.1303)

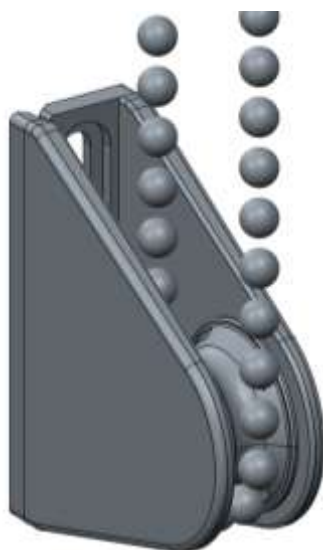

This device can be used in the following systems:

- Qbox 453 (with brass chain)
- Plus 2029 (with brass chain)
- Sidewinder 8230 – 8240 (with brass chain)
- Sidewinder 8277 (with brass chain)
- Rollbox 245 – 265 – 285 – 2115 – 565 – 585 – 260 – 560 (with aluminum guides)
- Rollbox 275 – 575 (with brass chain)

The length of the chain must comply with the rules of section “Child safety devices guidelines”

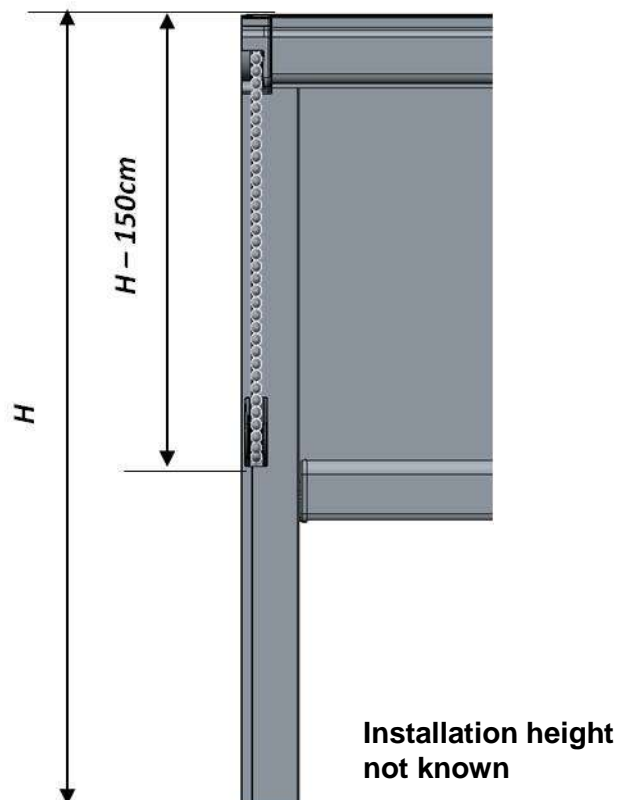
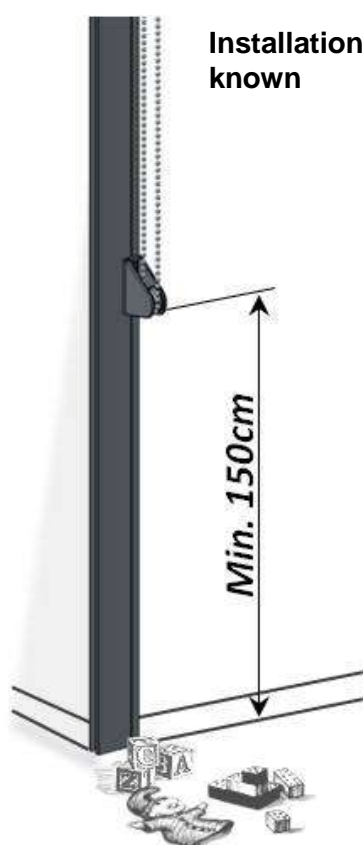

Insertion of the chain in the device 1303

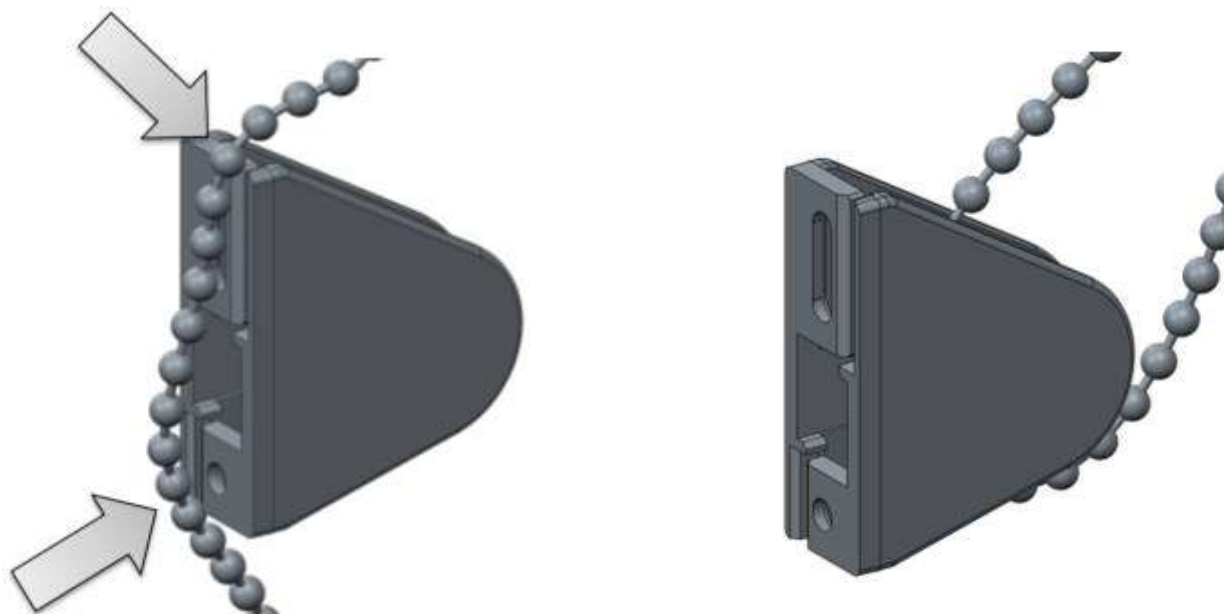

System assembly

Insert instruction into the bag and link bag and warning label to the chain with the provided strap.

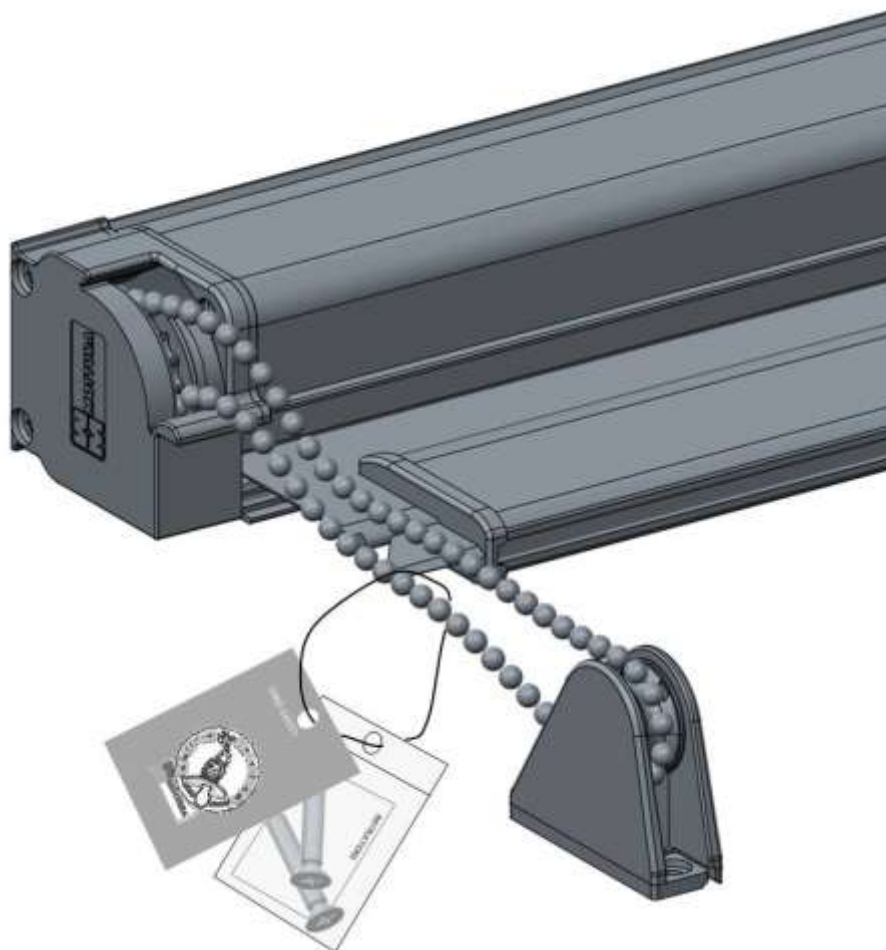

Insert the system in the plastic bag with the warning instructions printed.

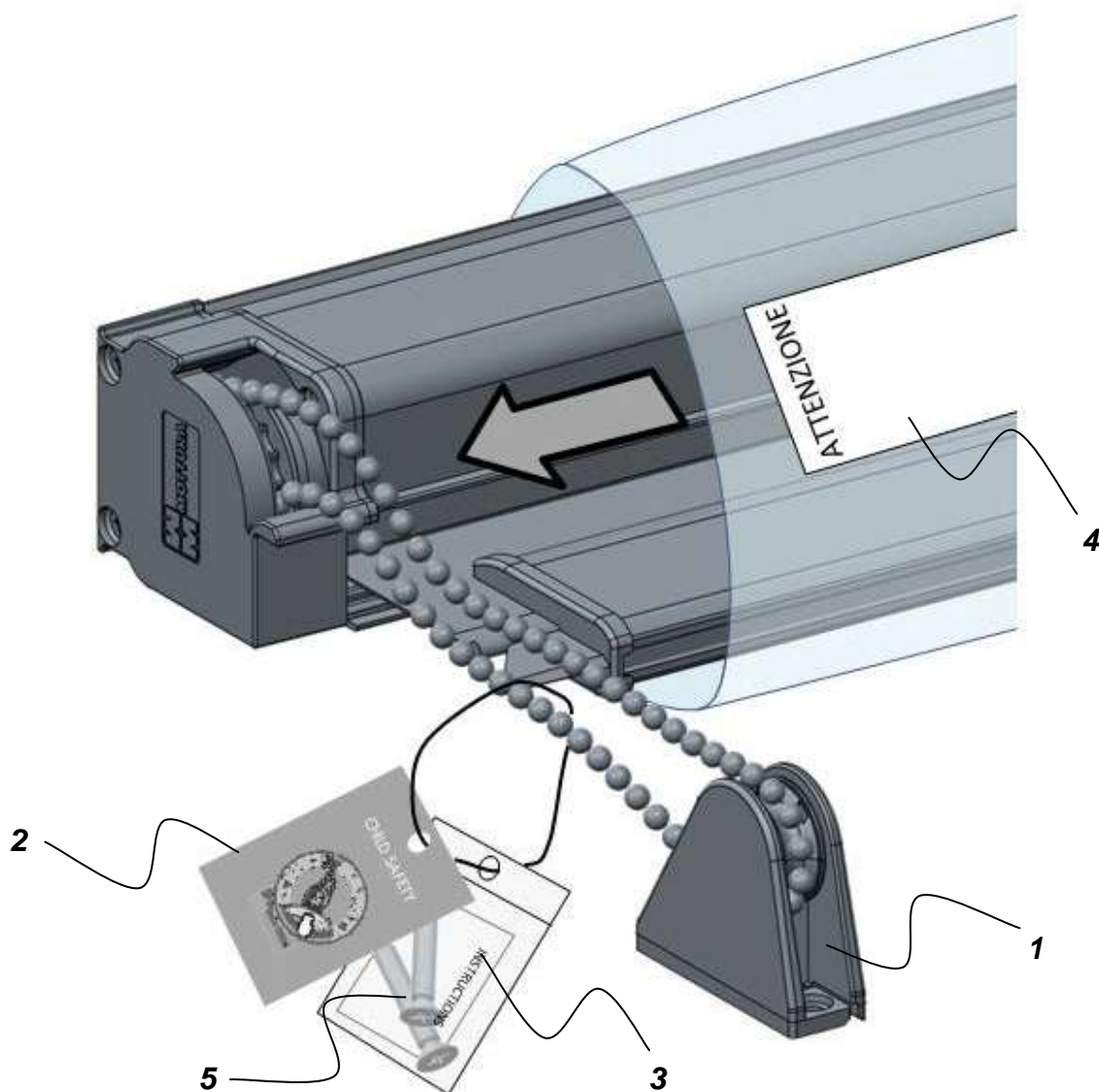

- 1 – 1303 – Fixed retaining device
- 2 – 1307 – Warning label
- 3 – 1308/3 – Assembly instructions
- 4 – 1061/64/65/66 – Plastic bag with warning instructions
- 5 – Fixing screws



Fixed retaining device (art.3636)



This device can be used in the following systems:

- Cord drawn draped systems
- Rotary 439 – 442 – 444 – 445
- Softbox 435 – 440 – 467/1
- Qbox 453 (with brass chain)
- Oriente 542-3-4-5-6 CC
- Plus 2029
- Sidewinder 8220 - 8230 – 8240 – 8273
- Sidewinder 8277
- Rollbox 245 – 265 – 285 – 2115 – 565 – 585 – 260 – 560
- Rollbox 275 – 575

The length of the chain must comply with the rules of section “Child safety devices guidelines”

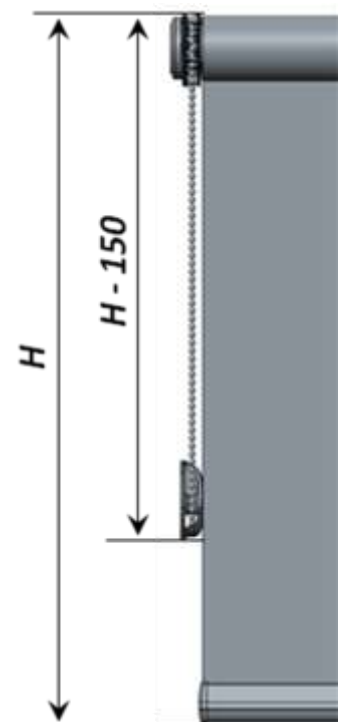

Installation height
not known

Insertion of the chain in the device 3636

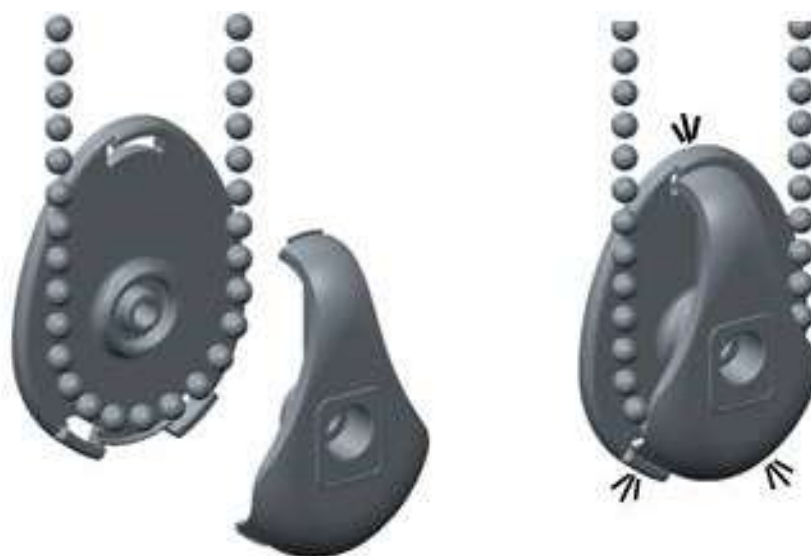

System assembly

Insert instruction and screw into the bag and link bag and warning label to the chain with the provided strap.

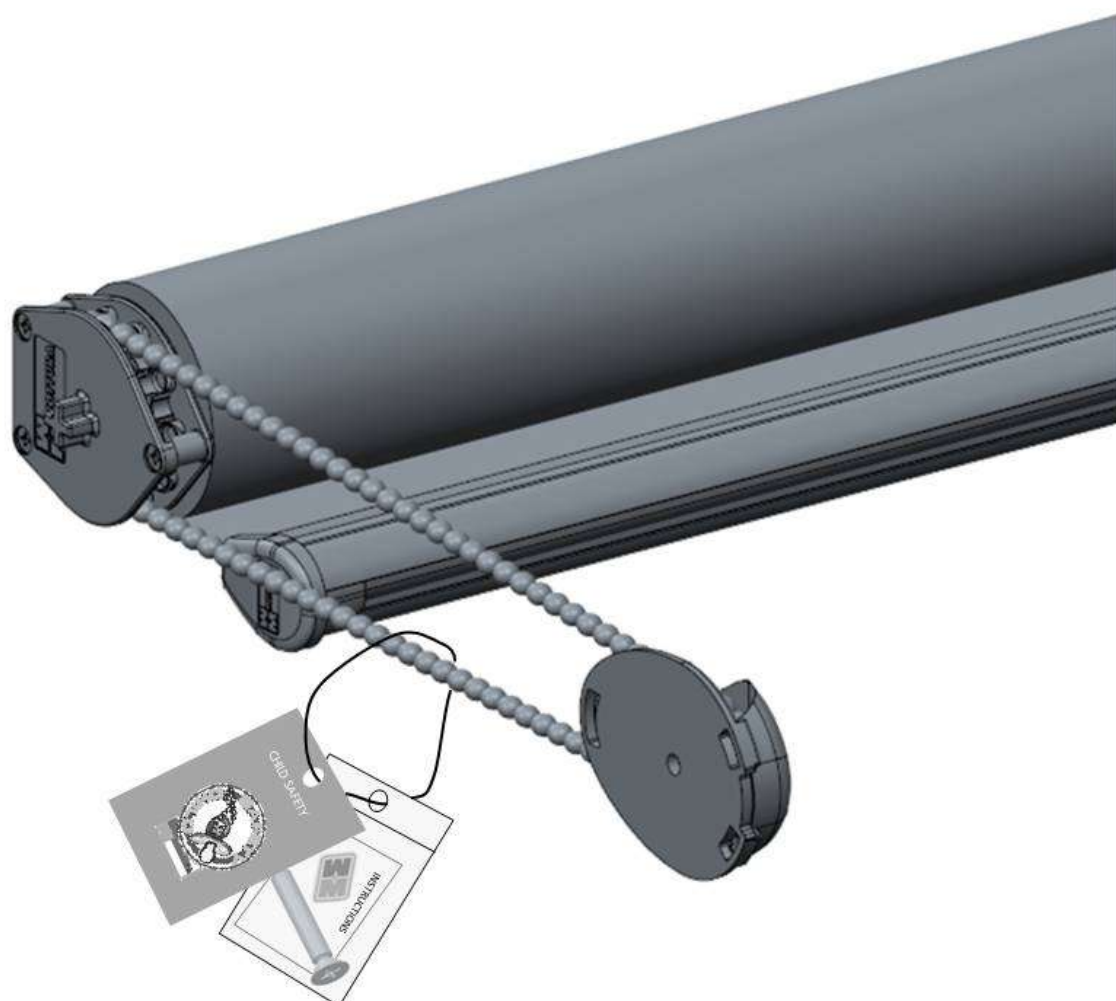

Insert the system in the plastic bag with the warning instructions printed.

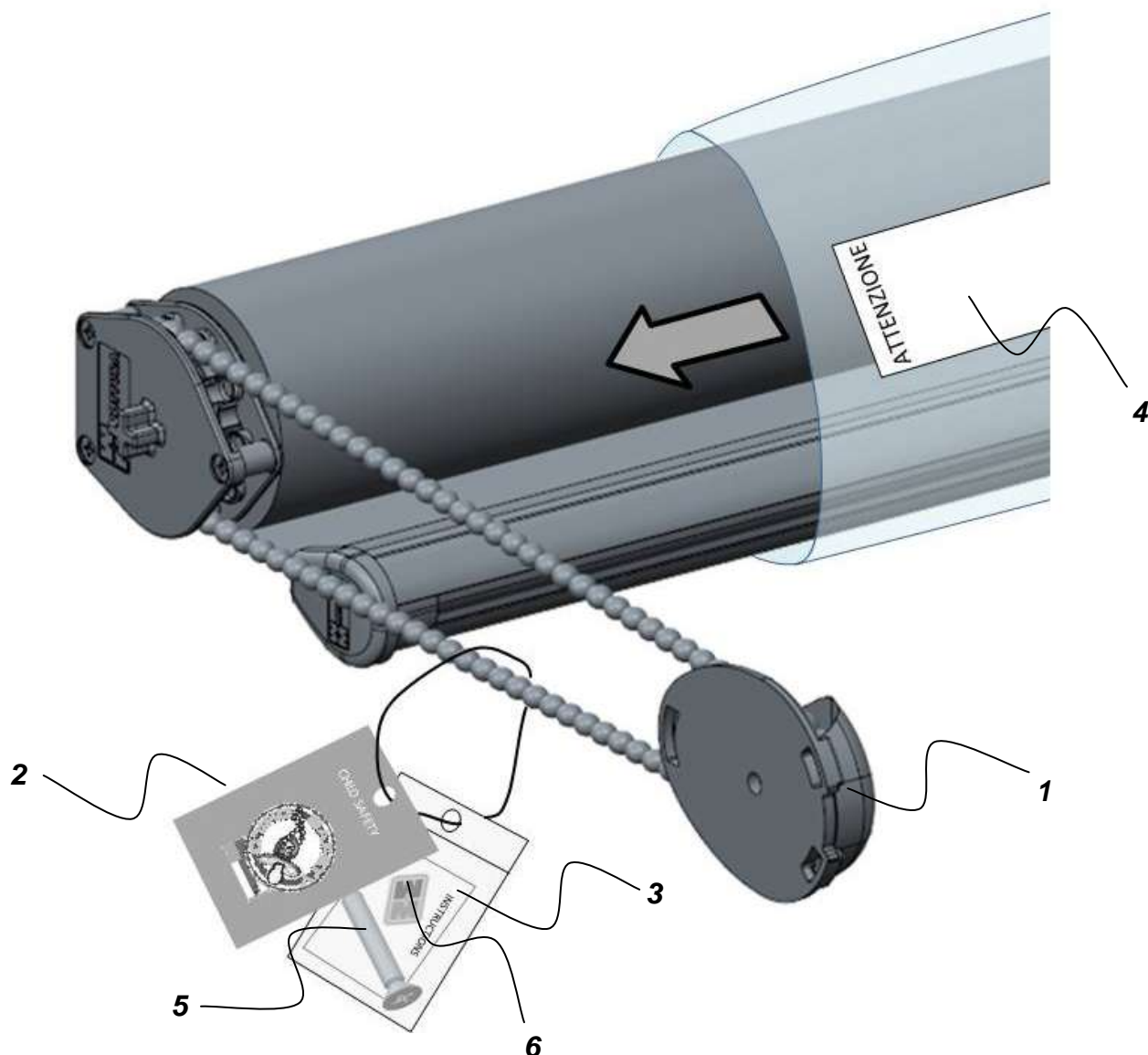

- 1 – 3636 – Fixed retaining device
- 2 – 1307 – Warning label
- 3 – 1308/6 – Assembly instruction
- 4 – 1061/64/65/66 – Plastic bag with warning instructions
- 5 – Fixing screw
- 6 – Z226/2 Aesthetic label



Safety chain tensioner (art.1304)

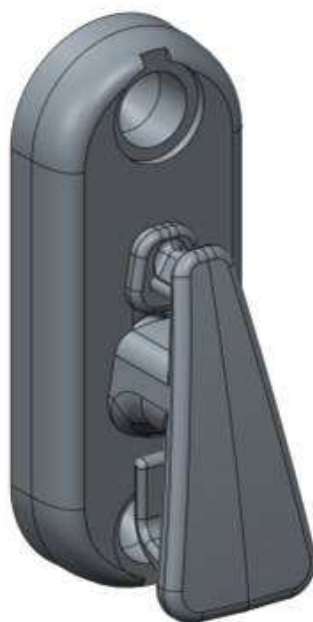

This device can be used in the following systems:

- Dual 359

The length of the chain must comply with the rules of section “Child safety devices guidelines”

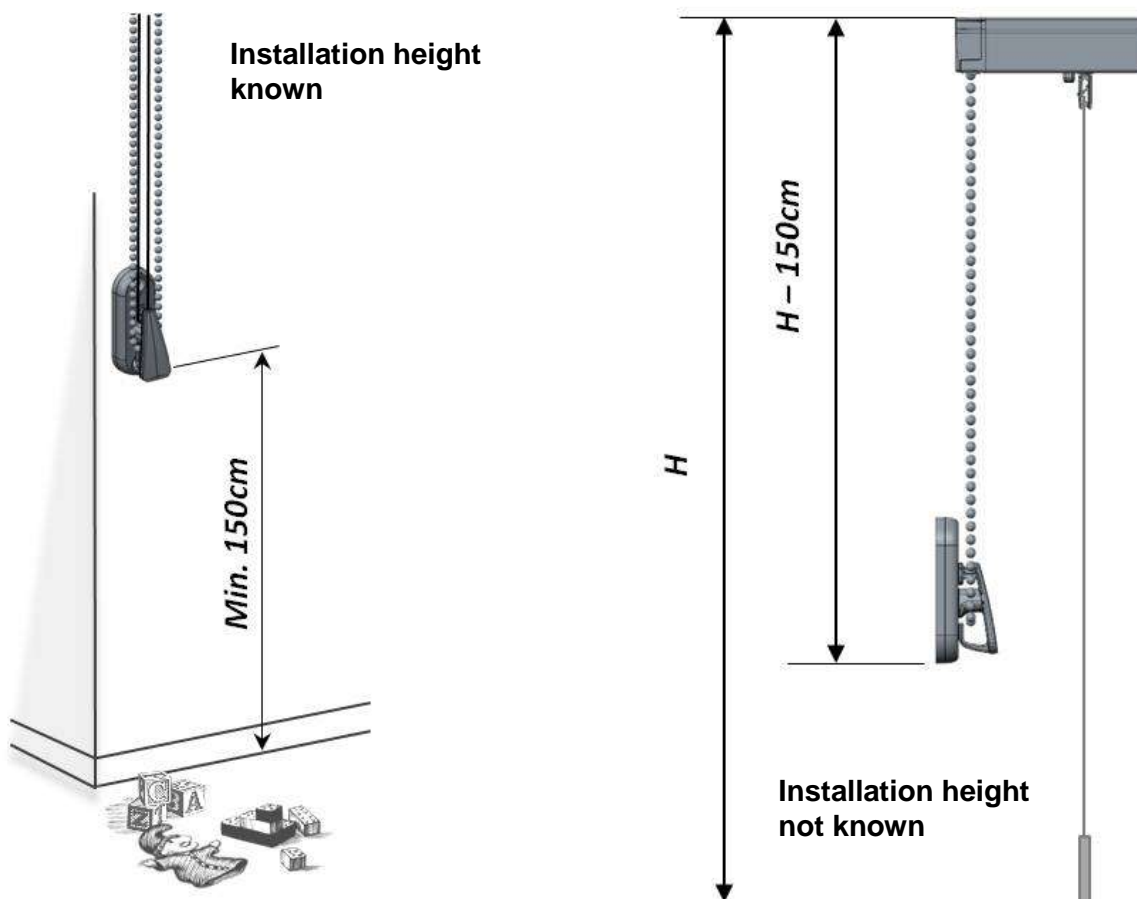

Insertion of the chain/cord in the device 1304

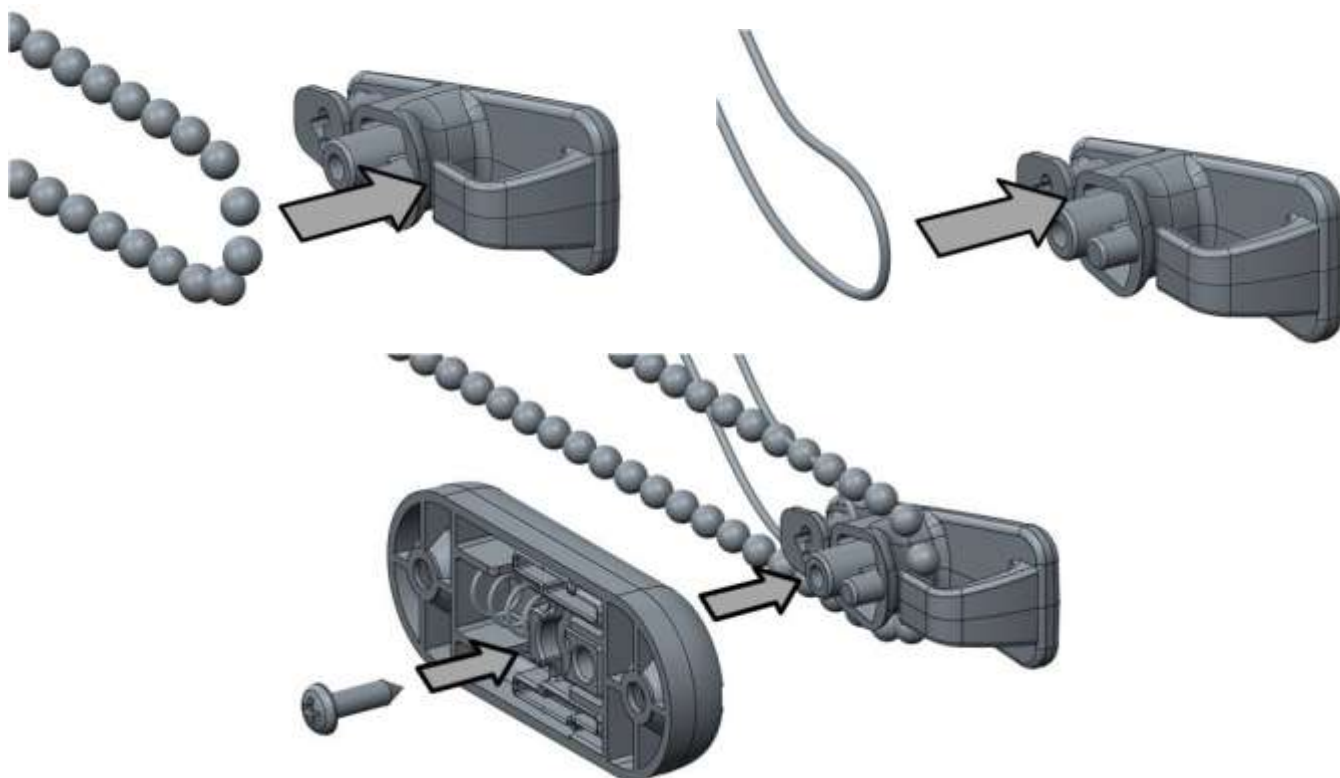

System assembly

Insert instruction and screws into the bag and link bag and warning label to the chain with the provided strap.

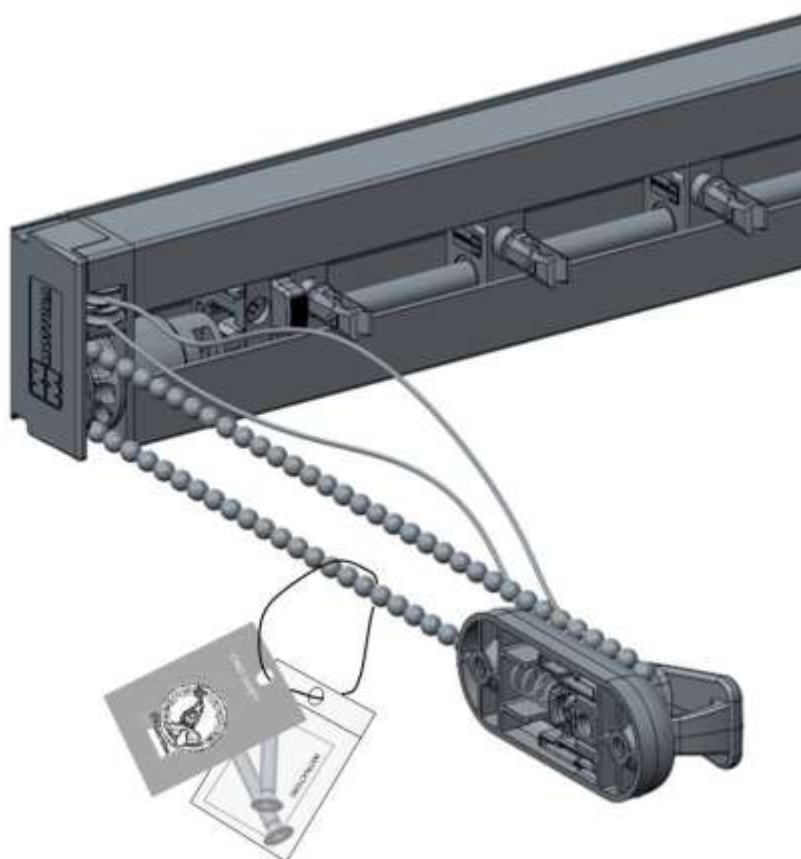

Insert the system in the plastic bag with the warning instructions printed.

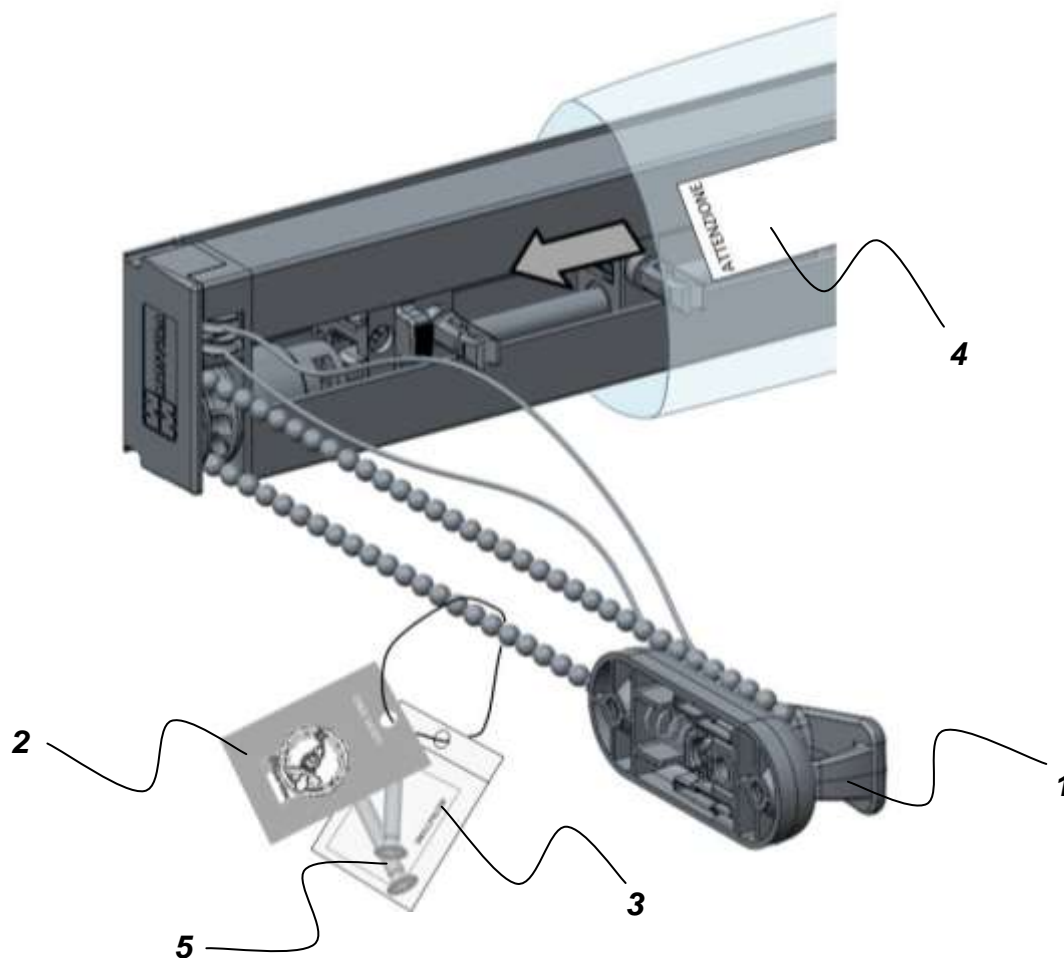

- 1 – 1304 – Fixed retaining device
- 2 – 1307 – Warning label
- 3 – 1308/4 – Assembly instructions
- 4 – 1061/64/65/66 – Plastic bag with warning instructions
- 5 – Fixing screws

Safety cord joint (art.1302) and accumulation device (art.8058)



This device can be used in the following systems:

- Basic 441 – 414 – 419 - 427
- Pli 353/1
- Veni version A

The length of the chain must comply with the rules of section “Child safety devices guidelines”

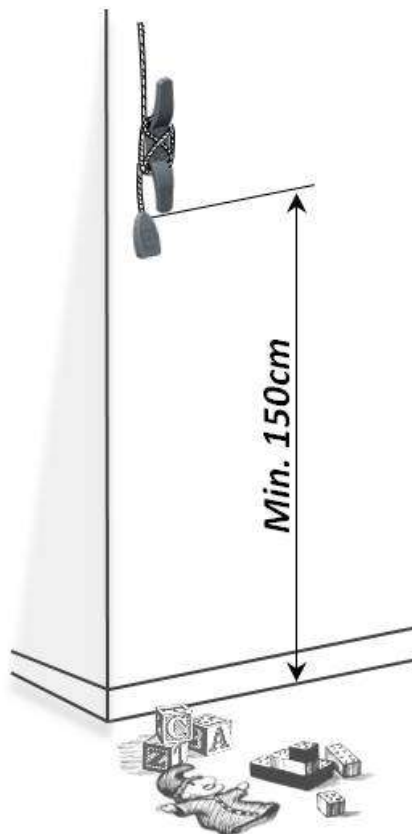

Assembly instructions for device 1302

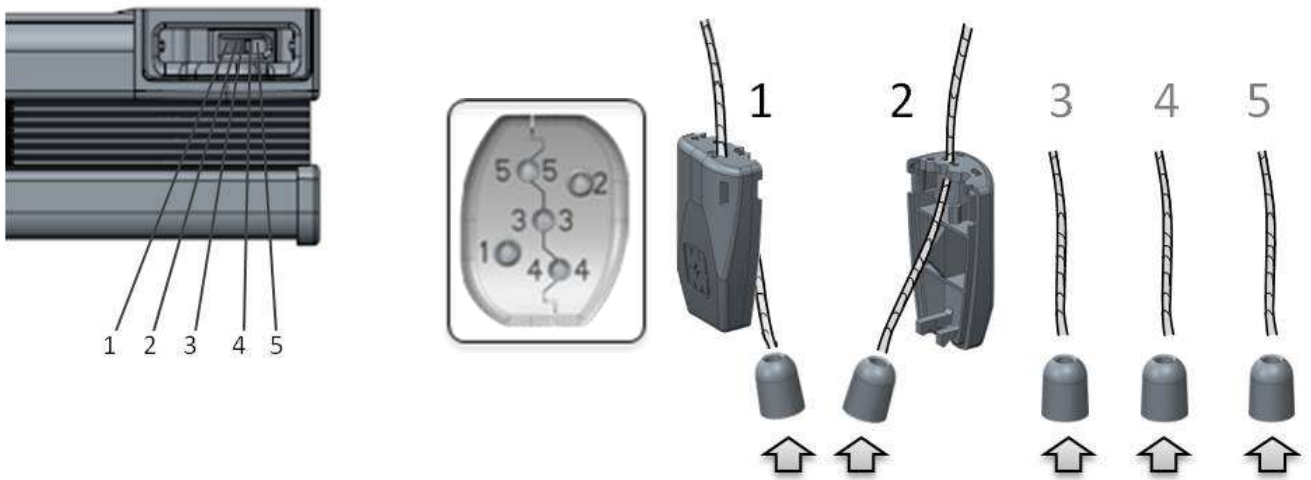

Ø1,5mm Basic 414-427



**Ø1mm Basic 441-419-
Venì**



Ø0,8mm Pli

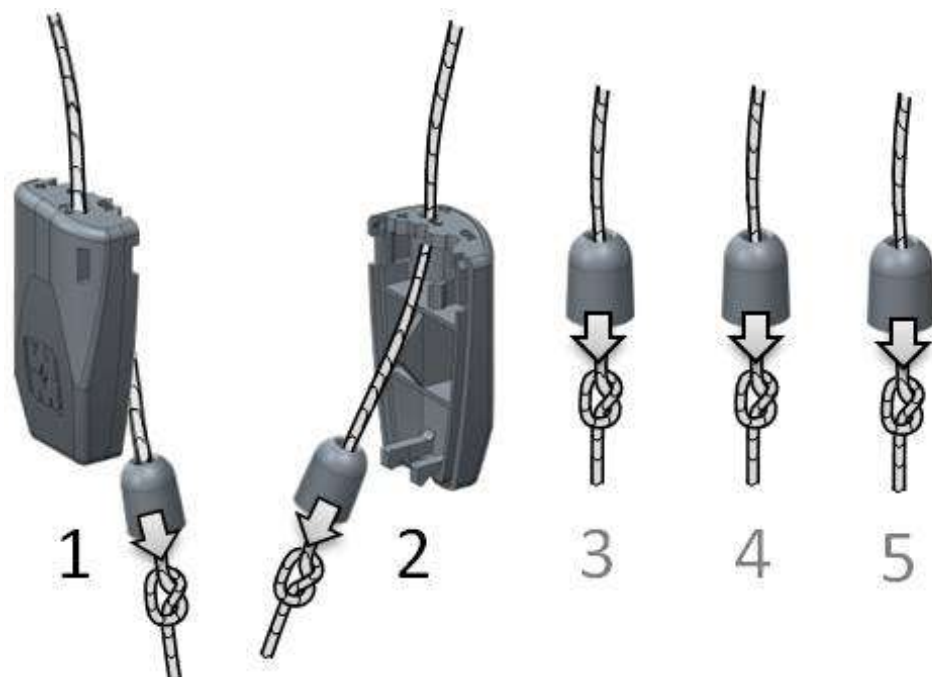

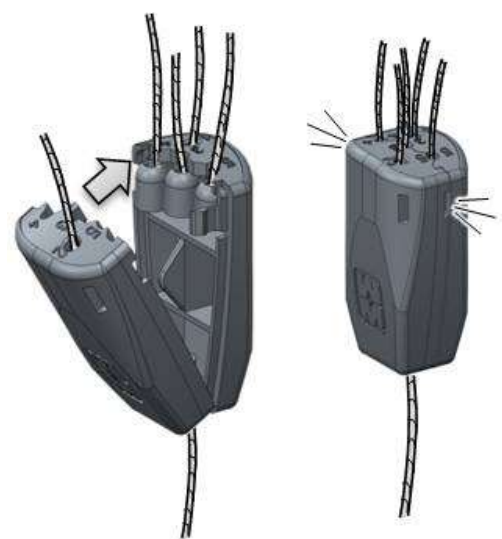

Cleat preparation

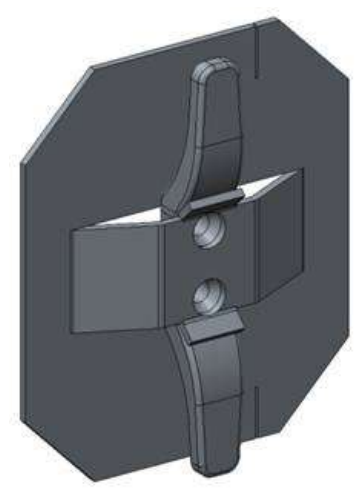
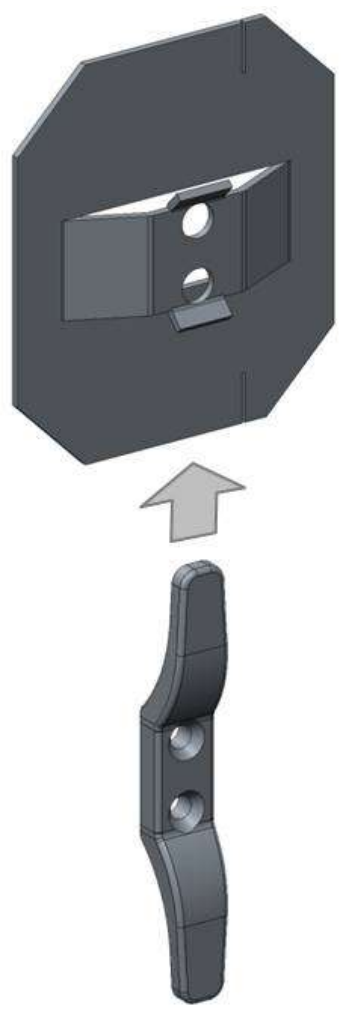

System assembly

Envelop cords for a length of max 150cm around the cleat pre-installed on the mounting board and get stuck cords in the notches of the board.

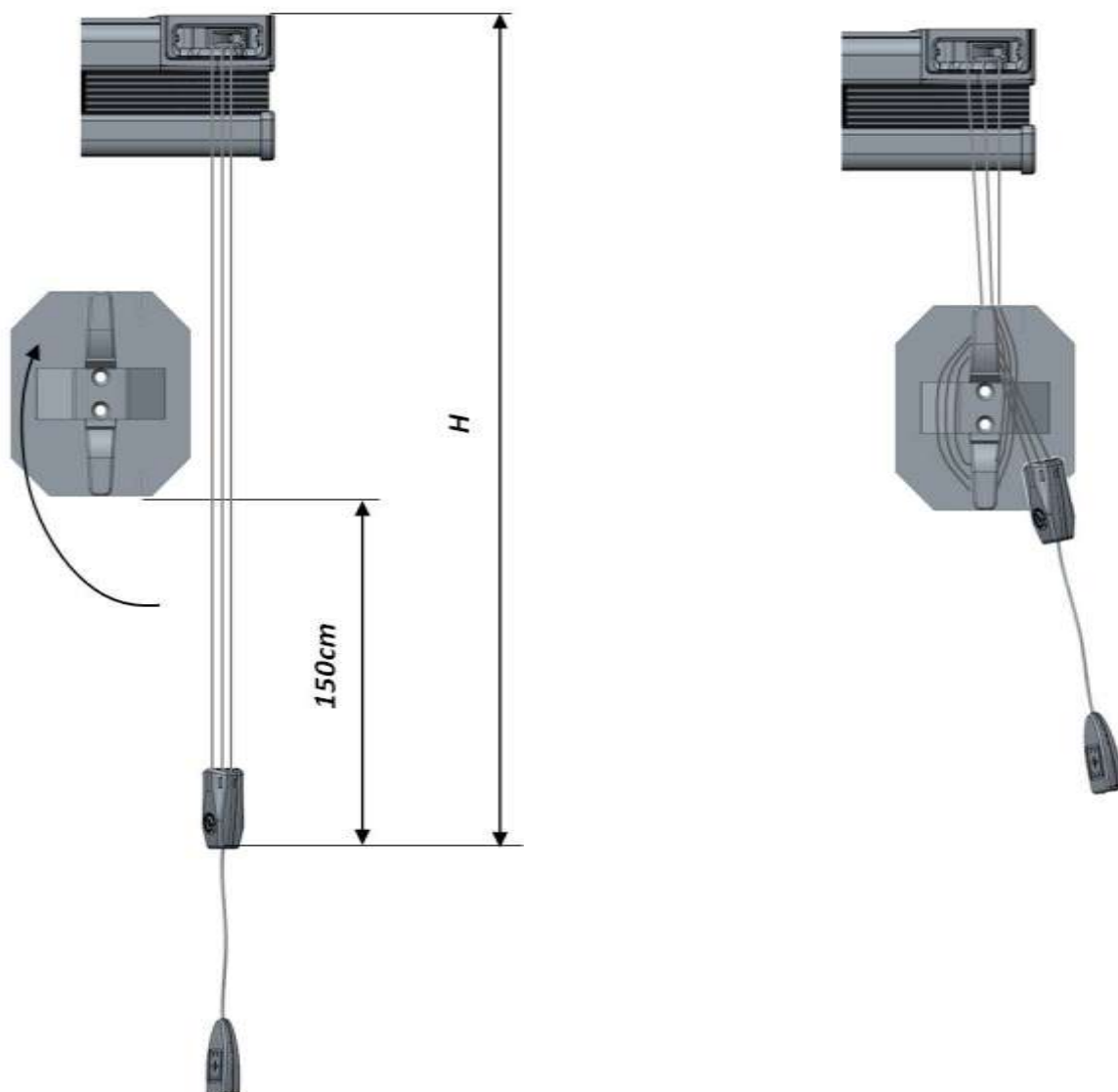

Insert the operation cords in the plastic bag with instructions and fixing screws.

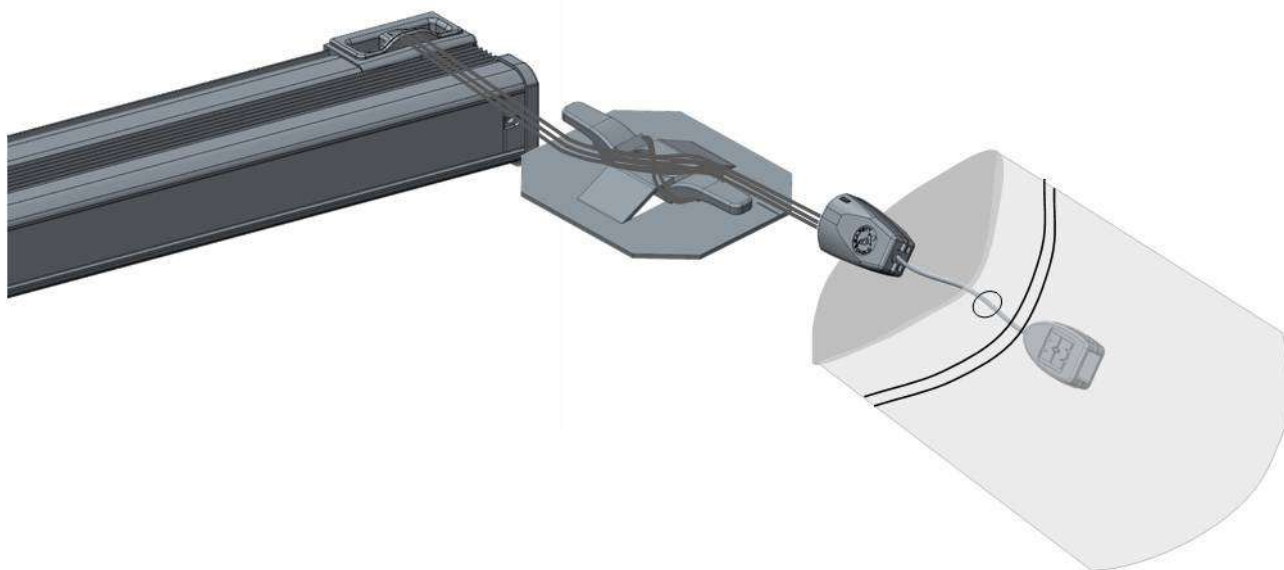

Close the bag and link it to the warning label with the provided strap.

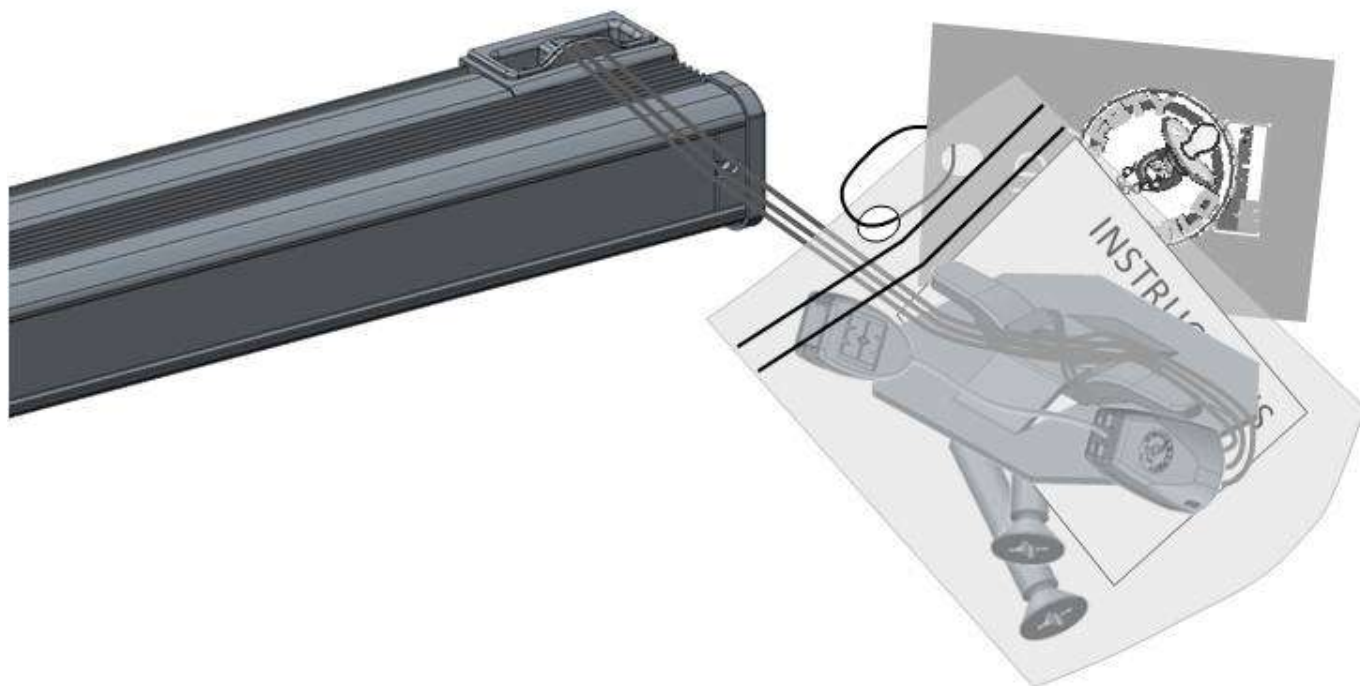

Insert the system in the plastic bag with the warning instructions printed.

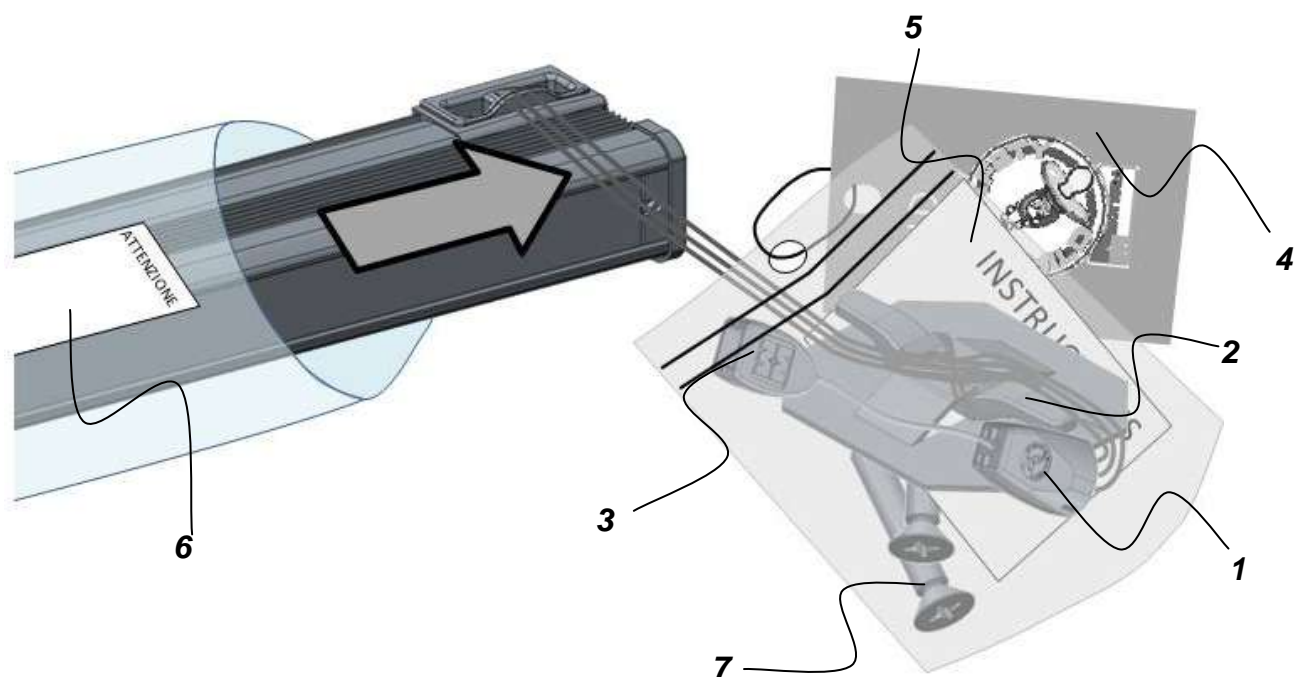

- 1 – 1302– Safety cord joint
- 2 – 8058 – Cleat
- 3 – 1193 – Tassel
- 4 – 1307 – Warning label
- 5 – 1308/2 – Assembly instructions
- 6 – 1061/64/65/66 – Plastic bag with warning instructions
- 7 – Fixing screws



Rear cord breakaway system (art.1305-1306)



This device can be used in the following systems:

- Basic 441 – 414 – 419 – 427
- Rotary 439 – 442 – 444 – 445 – 449
- Softbox 435/1 – 435/2 – 437 – 440/1 – 440/2 – 467/1 – 467/2 – 467/3
- Qbox 453 – 457

Assembly instructions for devices 1305-1306

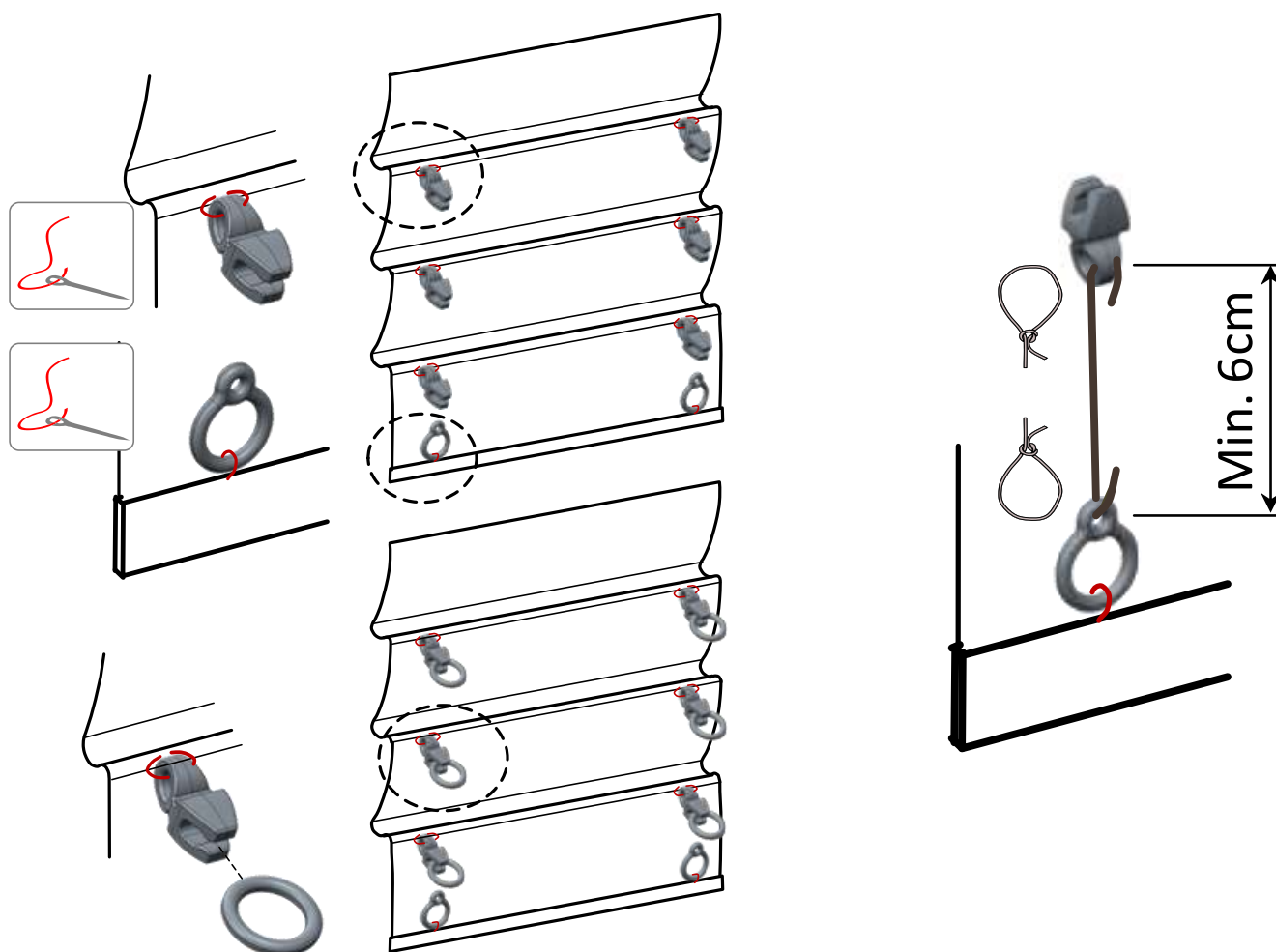

Hardware and fabric assembly

Insert the system in the plastic bag with the warning instructions printed.

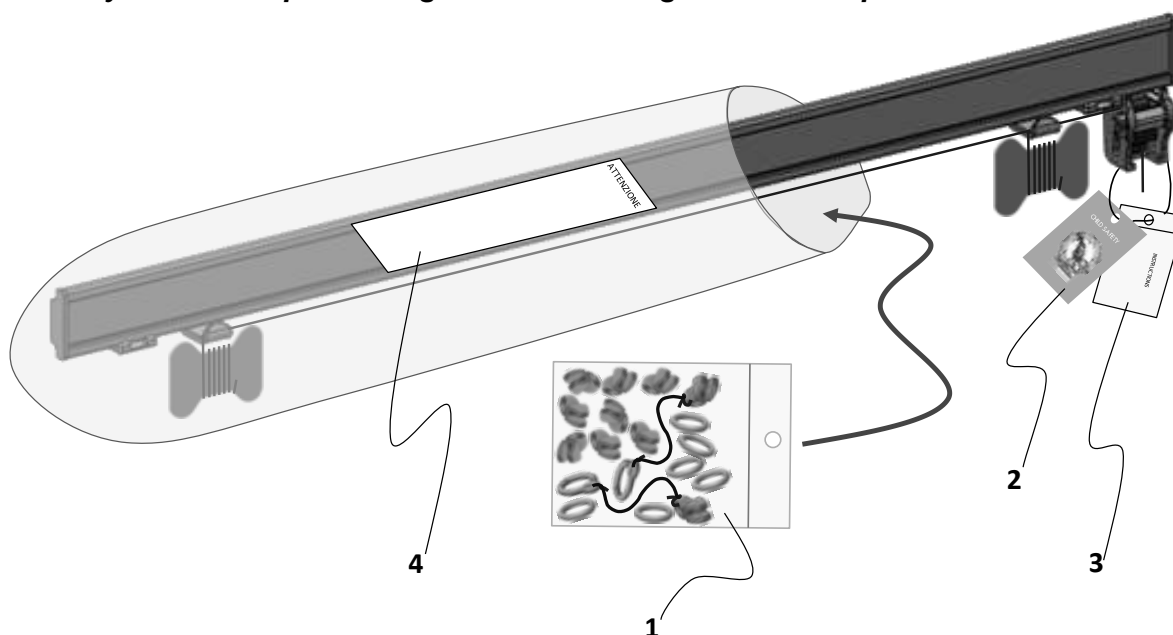

- 1 – 1305-1306– Safety cord guide ring and ring for cord fixing
- 2 – 1307 – Warning label
- 3 – 1308/5 – Assembly instructions
- 4 – 1061/64/65/66 – Plastic bag with warning instructions

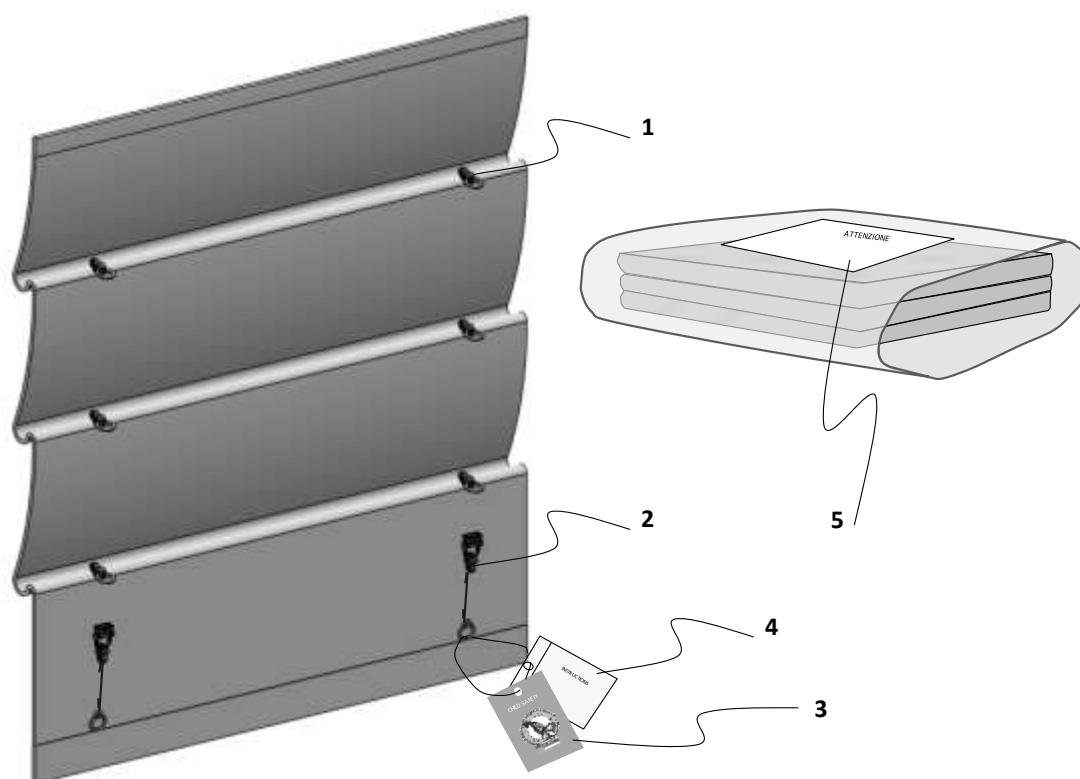

- 1 – 1305 – Safety cord guide ring
- 2 – 1306 – Safety ring for cord fixing
- 3 – 1307 – Warning label
- 4 – 1308/5 - Assembly instructions
- 5 – 1307 – Warning label

Assembled system

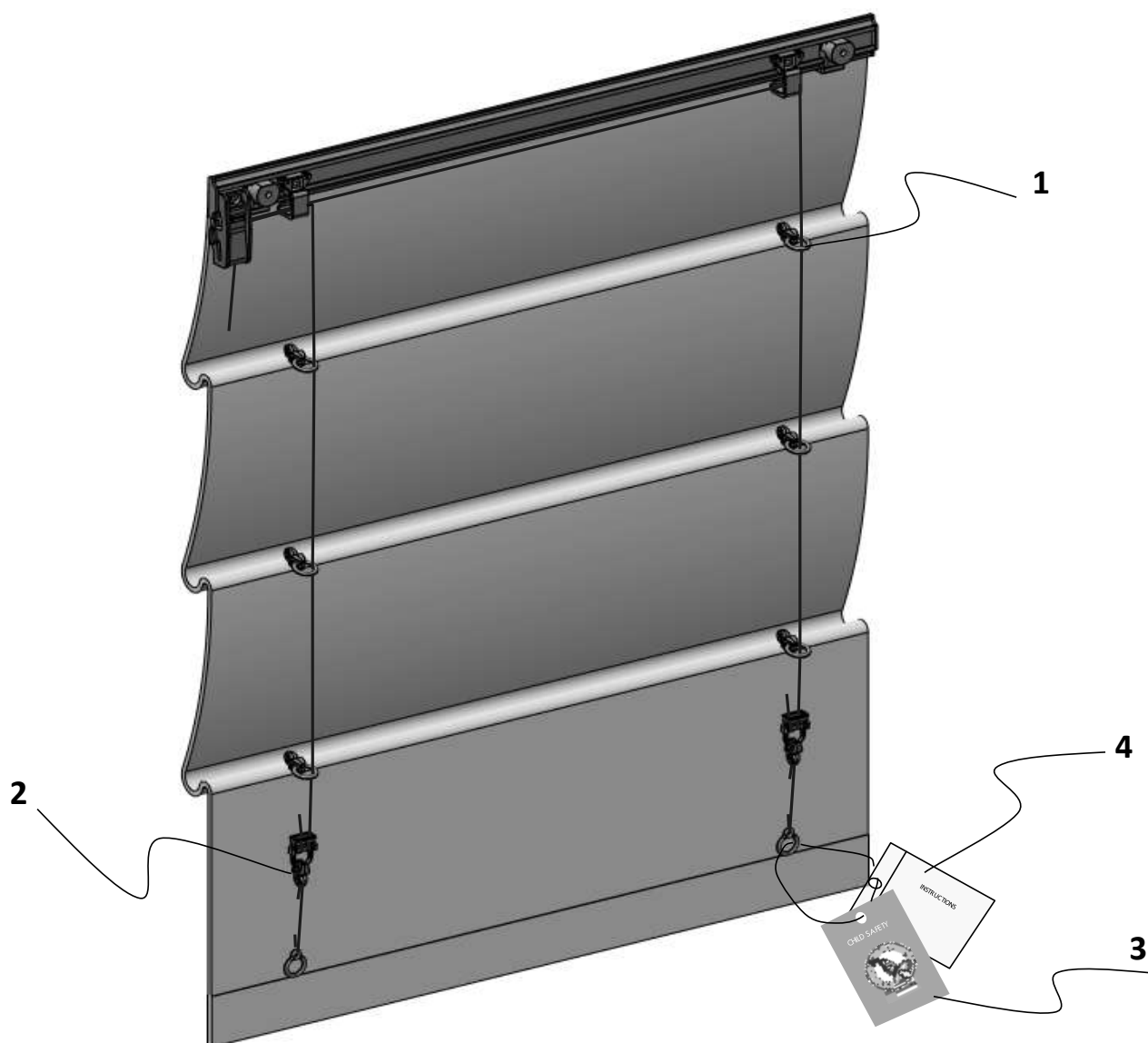

- 1 – 1305 – Safety cord guide ring
- 2 – 1306 – Safety ring for cord fixing
- 3 – 1307 – Warning label
- 4 – 1308/5 - Assembly instructions

Z 368 Rev.02
21/06/2017

Safety devices

Istruzioni di montaggio
Assembly Instructions

Mottura S.p.A.
Via XXV Luglio, 1
10090 - San Giusto Canavese (To) - Italia
Tel. (0039) 0124.49.49.49
Fax (0039) 0124.49.49.18
Internet: www.mottura.com
E-mail: mottura@mottura.com

Estemeed
Mottura S.p.A.
Via XXV Luglio, 1
10090 San Giusto C.se (TO)



The undersigned _____
as _____ of the company: _____
VAT n° _____ based in _____
Street address _____ ph _____ fax _____

DECLARES

have received, read and accepted the document
Z368 SAFETY DEVICES – assembly instructions

In witness thereof, _____

Date: _____