

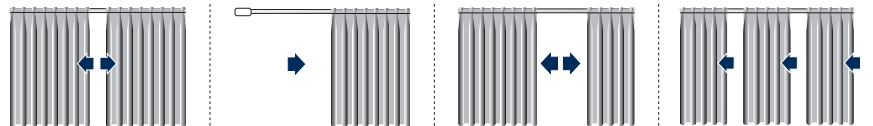

2.1.8

Spin 417





2.1.10

Spin 417



CARATTERISTICHE TECNICHE - SPECIFICATIONS - CARACTERÍSTICAS - CARACTERÍSTICAS - CARACTÉRISTIQUES - EIGENSCHAFTEN - KARAKTERISTIEKEN - ХАРАКТЕРИСТИКИ

- Profilo in lega d'alluminio estrusa 6060 T6 UNI 8278
 - Larghezza 8 mm; Altezza 22 mm
 - Canale di scorrimento 4,5 mm
 - Raggio di curvatura minima:
curve a 90°: 10 cm
curve ad ampio raggio: 50 cm
 - Finitura superficiale:
verniciatura poliester bianco RAL 9016 lucido
verniciatura poliester nero RAL 9005 lucido
anodizzato argento - oro - bronzo
altri colori a richiesta
 - Accessori in acetilica autolubrificante
- 6060 T6 UNI 8278 extruded aluminium alloy track
 - Width 8 mm; Height 22 mm
 - Sliding channel 4.5 mm
 - Minimum radius of curvature:
90° curves: 10 cm
wide radius curves: 50 cm
 - Surface finish:
RAL 9016 white polyester paint polished
RAL 9005 black polyester paint polished
silver - gold - bronze anodised
available on request
 - Self-lubricating acetylic accessories
- Perfil en aleación de aluminio extruido 6060 T6 UNI 8278
 - Anchura 8 mm - Altura 22 mm
 - Canal de deslizamiento 4,5 mm
 - Radio de curvatura mínima:
curvas en 90°: 10 cm
curvas de amplio ángulo: 50 cm
 - Acabados de la superficie:
pintura poliéster blanca RAL 9016 brillante
pintura poliéster negra RAL 9005 brillante
anodizado plata - oro - bronce
otros colores bajo petición
 - Accesorios de acetálico autolubrificante
- Perfil de liga de alumínio extrudido 6060 T6 UNI 8278
 - Largura 8 mm; Altura 22 mm
 - Calha de deslizamento 4,5 mm
 - Raio de curvatura mínimo:
curvas de 90°: 10 cm - curvas de raio amplo: 50 cm
 - Acabamento superficial:
tinta de poliéster branca RAL 9016 polido
tinta de poliéster preta RAL 9005 polido
anodizado prateado - dourado - bronze
outras cores a pedido

- Acessórios de resina acetálica autolubrificante
- Profil en alliage d'aluminium extrudé 6060 T6 UNI 8278
 - Largeur 8 mm; Hauteur 22 mm
 - Rail de coulissement 4,5 mm
 - Rayon minimum:
courbes à 90°: 10 cm
courbes à grand rayon: 50 cm
 - Finition superficielle:
peinture polyester blanc RAL 9016 brillant
peinture polyester noir RAL 9005 brillant
anodisé argent - or - bronze
autres couleurs sur demande
 - Accessoires en résine d'acétal autolubrifiante
- Profil aus extrudierter Alu-Legierung 6060 T6 UNI 8278
 - Breite 8 mm; Höhe 22 mm
 - Laufkanal 4,5 mm
 - Kleinster Biegeradius:
90°-Kurven: 10 cm
Kurven mit großem Radius: 50 cm
 - Oberflächen-Finish:
Polyesterlackierung Weiß RAL 9016 poliert
Polyesterlackierung Schwarz RAL 9005 poliert
Alu eloxiert - Messing - Bronze
andere Farben auf Anfrage
 - Zubehör aus selbstschmierendem Acetal
- Profiel in geëxtrudeerde aluminium legering 6060 T6 UNI 8278
 - Breedte 8 mm; hoogte 22 mm
 - Glijkanaal 4,5 mm
 - Minimum straal van verbuiging op 90°: 10 cm
op grote straal: 50 cm
 - Oppervlaktebehandeling : polyesterlak wit RAL 9016 gepolijst
RAL 9005 zwart polyester lak gepolijst
geanodiseerd zilver, brons of goudkleur
andere kleuren op aanvraag
 - Onderdelen in zelfsmerend acetyl
- Профиль из экструдированного алюминиевого сплава 6060 T6 UNI 8278
 - Ширина 8 мм; Высота 22 мм
 - Желоб 4,5 мм
 - Минимальный радиус поворота:
повороты 90°: 10 см
повороты с большим радиусом: 50 см
 - Отделка поверхности:
полиэфирная окраска в белый цвет RAL 9016 полированный
полиэфирная окраска в черный цвет RAL 9005 полированный
анодирование серебро - золото - бронза
другие цвета — по запросу
 - Принадлежности из самосмазывающейся ацеталовой пластмассы

SISTEMAZIONI - APPLICATION - COLOCACIÓN - APLICAÇÕES MONTAGE - MONTAGE - TOEPASSING - ВАРИАНТЫ УСТАНОВКИ

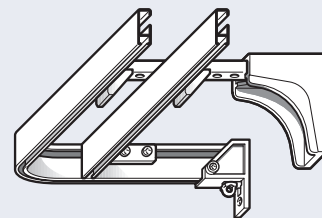
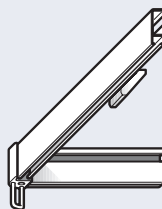
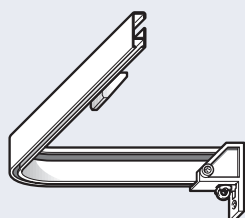
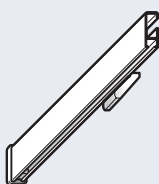

INSTALLAZIONE

INSTALLATION
 INSTALACIÓN
 INSTALAÇÃO
 INSTALLATION
 INSTALLATION
 INSTALLATIE
 УСТАНОВКА

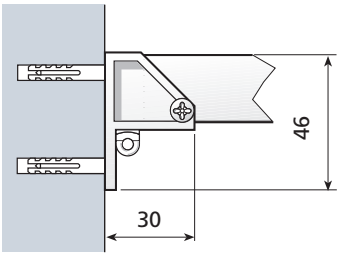

4356

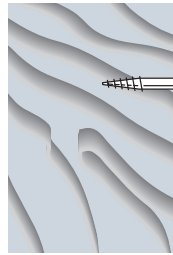

4112

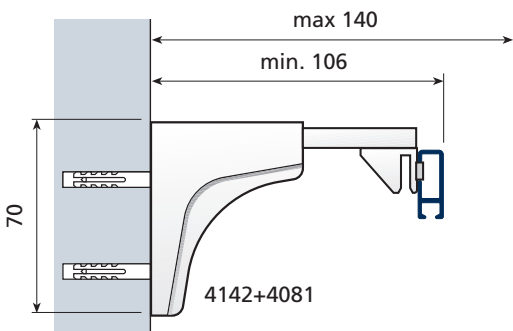

4142+4081

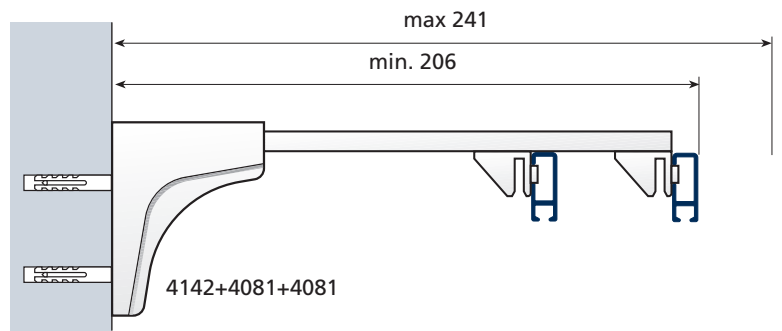

4142+4081+4081

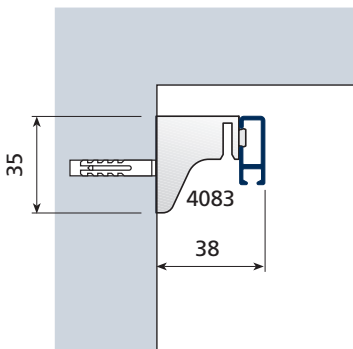

4083

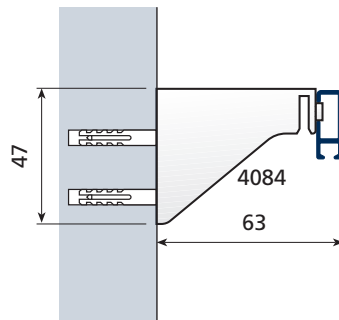

4084

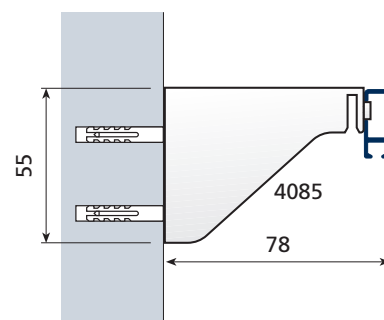

4085

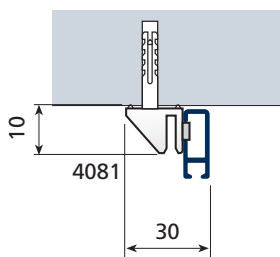

4081

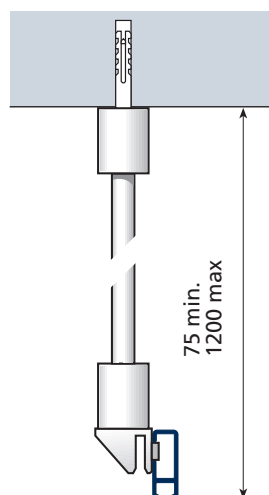

4135+4081



2.1.12

Spin 417

SOSPENSIONE QUADRI

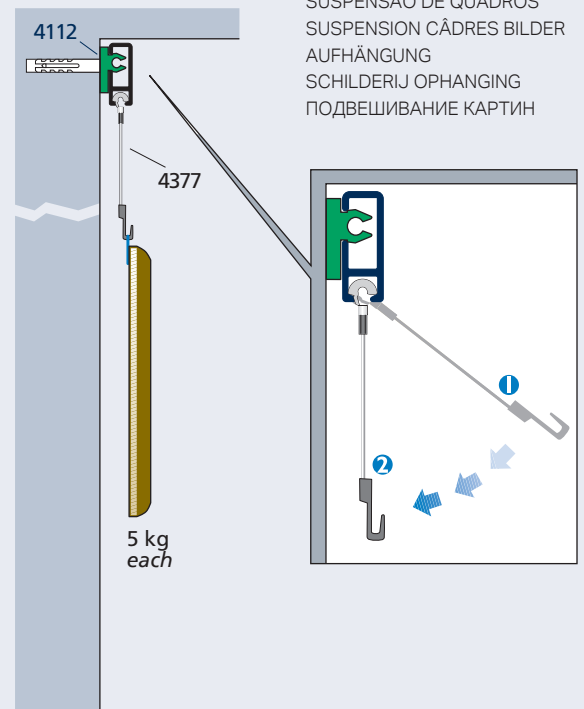
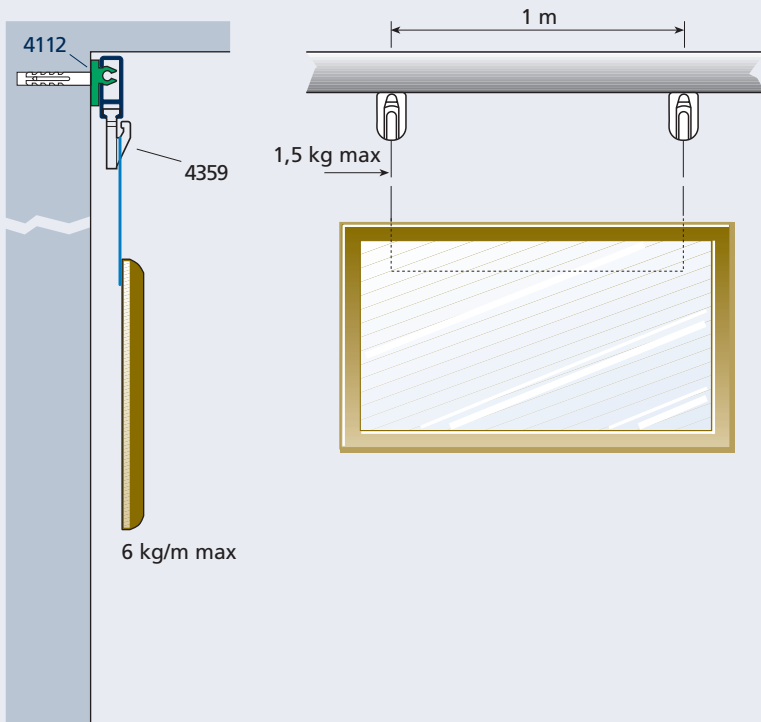

PICTURES HANGING
 SUSPENSIÓN CUADROS
 SUSPENSÃO DE QUADROS
 SUSPENSION CÂDRES BILDER
 AUFHÄNGUNG
 SCHILDERIJ OPHANGING
 ПОДВЕШИВАНИЕ КАРТИН

UTILIZZO

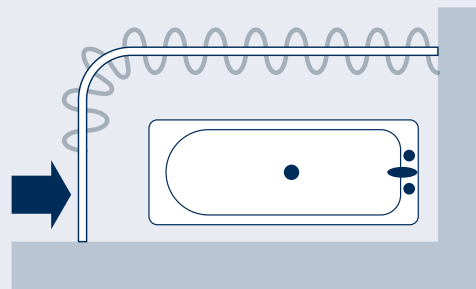
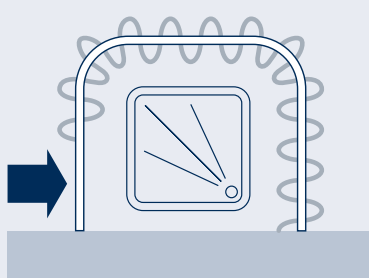

USE
 USO
 USO
 UTILISATION
 ANWENDUNG
 GEBRUIK
 ХАРАКТЕРИСТИКА

CURVE

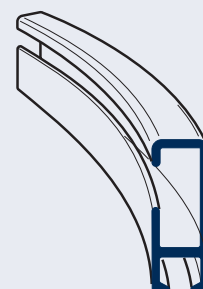
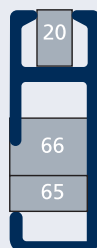
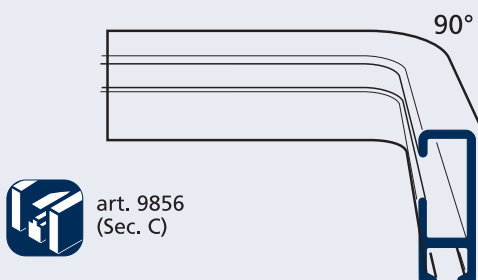

BENDING
 CURVAS
 CURVAS
 COURBAGE
 BOGEN
 BUIGEN
 ИЗГИБ

