

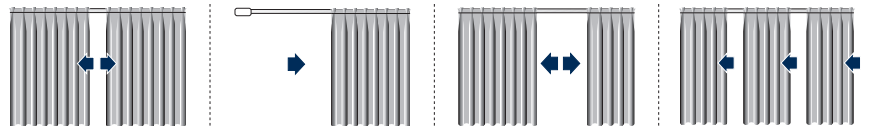

1.2.6

Teatro 404





1.2.8

Teatro 404



CARATTERISTICHE TECNICHE - SPECIFICATIONS CARACTERÍSTICAS - CARACTERÍSTICAS - CARACTÉRISTIQUES EIGENSCHAPTEN - KARAKTERISTIEKEN - ХАРАКТЕРИСТИКИ

- Profilo in lega d'alluminio estrusa 6060 T6 UNI 8278
 - Larghezza 57 mm; Altezza 32,5 mm
 - Canale di scorrimento 6,5 mm
 - Finitura superficiale:
verniciatura poliestere bianco RAL 9016 lucido
altri colori a richiesta
 - Carrucole in termoplastico antiurto con cuscinetti a sfere
 - Accessori in acetalica autolubrificante
- 6060 T6 UNI 8278 extruded aluminium alloy track
 - Width 57 mm; Height 32.5 mm
 - Sliding channel 6.5 mm
 - Surface finish:
RAL 9016 white polyester paint polished
available on request
 - Shockproof thermoplastic pulleys with ball bearings
 - Self-lubricating acetylic accessories
- Perfil en aleación de aluminio extruido 6060 T6 UNI 8278
 - Anchura 57 mm - Altura 32,5 mm
 - Canal de deslizamiento 6,5 mm
 - Acabado de la superficie:
pintura poliéster blanca RAL 9016 brillante
otros colores bajo petición
 - Poleas en termoplástico endurecido con cojinetes de bolas
 - Accesorios de acetálico autolubrificante
- Perfil de liga de alumínio extrudido 6060 T6 UNI 8278
 - Largura 57 mm; Altura 32,5 mm
 - Calha de deslizamento 6,5 mm
 - Acabamento superficial: tinta de poliéster branca RAL 9016 polido
outras cores a pedido
 - Polias de material termoplástico anti-choque com rolamentos
de esferas
 - Acessórios de resina acetálica autolubrificante
- Profil en alliage d'aluminium extrudé 6060 T6 UNI 8278
 - Largeur 57 mm; Hauteur 32,5 mm
 - Rail de coulissement 6,5 mm
 - Finition superficielle:
peinture polyester blanc RAL 9016 brillant
autres couleurs sur demande
 - Poulies en matériau thermoplastique antichoc avec coussinets
à billes
 - Accessoires en résine d'acétal autolubrifiante
- Profil aus extrudierter Alu-Legierung 6060 T6 UNI 8278
 - Breite 57 mm; Höhe 32,5 mm
 - Laufkanal 6,5 mm
 - Oberflächen-Finish:
Polyesterlackierung Weiß RAL 9016 poliert
andere Farben auf Anfrage
 - Umlenkungen aus stoßfestem Thermoplast mit Kugellagern
 - Zubehör aus selbstschmierendem Acetal
- Geëxtrudeerd aluminium profiel 6060 T6 UNI 8278
 - Breedte 57 mm; hoogte 32,5 mm
 - Glijkanaal 6,5 mm
 - Oppervlaktebehandeling:
polyesterlak wit RAL 9016 gepolijst
andere kleuren op aanvraag
 - Poelies in schokvrij thermoplastic en rollen met kogellagers
 - Onderdelen in zelfsmierend acetyl
- Профиль из экструдированного алюминиевого сплава
6060 T6 UNI 8278
 - Ширина 57 мм; Высота 32,5 мм
 - Желоб 6,5 мм
 - Отделка поверхности:
полиэфирная окраска в белый цвет RAL 9016 полированный
другие цвета — по запросу
 - Шкивы из противоударного термопласта с
шарикоподшипниками
 - Принадлежности из самосмазывающейся ацеталовой
пластмассы

INSTALLAZIONE

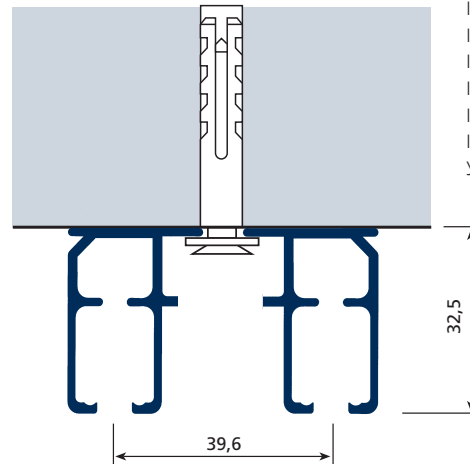

INSTALLATION
INSTALACIÓN
INSTALAÇÃO
INSTALLATION
INSTALLATION
INSTALLATIE
УСТАНОВКА

CONFEZIONI CONSIGLIATE

A RAPPORTO DI ARRICCIAURA
THE SPACE BETWEEN THE PLEATS
RAPPORT DE FRUNCIDO
RELAÇÃO DE FRANZIDO
INDIQUE LA DISTANCE ENTRE PLUS
GIBT DEN RAFFRAPPORT AN
GEEFT DE AFSTAND TUSSEN DE PLOOIEN AAN
ВИД ДРАПИРОВКИ

SUGGESTED STYLES OF CURTAINS
TIPOS DE CONFECCIÓN
TIPOS DE CORTINAS ACONSELHADOS
CONFECTION CONSEILLÉE
EMPFOHLENE VORHANGBÄNDER
AANBEVOLEN CONFECTIE
МОДЕЛЬ

B NASTRO - TAPE
CINTA - FITA
GALON - BAND
ЛИНТ - ЛЕНТА

	A	B
	1:2	art. 776 - h 80 mm art. 795/... - h 80 mm

INGOMBRI

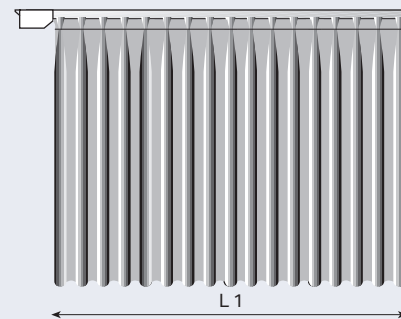

OVERALL
DIMENSIONS
ESPEORES
DIMENSÃO
ENCOMBREMEN
RAUMBEDARF
PAKKET
ГАБАРИТЫ

**L2 ≈ 18% L1**

L 2

