

Stralys 477

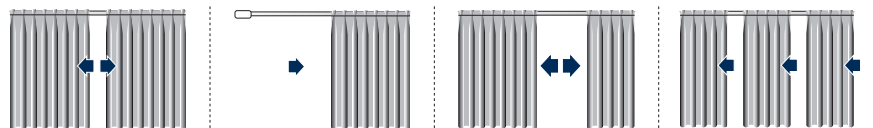

1.1.63





CARATTERISTICHE TECNICHE - SPECIFICATIONS CARACTERÍSTICAS - CARACTERÍSTICAS - CARACTÉRISTIQUES EIGENSCHAFTEN - KARAKTERISTIEKEN - ХАРАКТЕРИСТИКИ

- Profilo in lega d'alluminio estrusa 6060 T6 UNI 8278 - 100x15 mm
 - Canale di scorrimento: 6 mm
 - Finiture superficiali:
verniciatura poliestere bianco RAL 9016 lucido e opaco
verniciatura poliestere nero RAL 9005 lucido e opaco
bronzo; argento anodizzato; vaniglia; tortora;
altri colori a richiesta
 - Carrucole in termoplas. antiurto verniciato con ruote su perni in acciaio
 - Supporti in alluminio per installazione a parete o in libera sospensione, chiave girevole in metallo per installazione a soffitto
 - Sormonto per tende arricciate 5,5 cm
 - Accessori in acetalica autolubrificante
- Profile in extruded aluminium alloy 6060 T6 UNI 8278 - 100x15 mm
 - Slide track: 6 mm
 - Surface finish:
RAL 9016 white polyester paint polished and matt;
RAL 9005 black polyester paint, bronze, silver anodised,
vanilla, dove grey;
available on request
 - Painted impact-resistant thermoplastic pulleys with wheels on steel pins
 - Aluminium supports for wall mounting or free suspension, revolving metal key for ceiling mounting
 - 5.5 cm overlap for draped curtains
 - Accessories in self-lubricating Delrin
- Perfil en aleación de aluminio extrudida 6060 T6 UNI 8278 - 100x15 mm
 - Canal de deslizamiento: 6 mm
 - Acabados superficiales:
pintura poliéster blanca RAL 9016 brillante y mate;
pintura poliéster negra RAL 9005 brillante y mate;
bronce, anodizado plata, vainilla, gris paloma
otros colores bajo petición
 - Garruchas en material termoplástico antichoque pintado, con ruedas sobre pernos de acero
 - Soportes en aluminio para instalación en pared o en suspensión libre, chaveta giratoria de metal para la instalación en techo
 - Sobreposición de 5,5 cm para cortinas plisadas
 - Accesorios en acetálico autolubrificante
- Perfil de liga de alumínio extrudido 6060 T6 UNI 8278 - 100x15 mm
 - Calha de deslizamento: 6 mm
 - Acabamentos superficiais:
tinta de poliéster branca RAL 9016 polido e mate
tinta de poliéster preta RAL 9005 polido e mate
bronze; anodizado prateado; baunilha; cinza claro
outras cores a pedido
 - Polias de material termoplástico anti-choque pintado com rodas sobre pernos de aço
 - Suportes de alumínio para instalação na parede ou em suspensão livre, chaveta giratória de metal para instalação no tecto
 - Sobreposição para cortinas franzidas 5,5 cm
 - Acessórios de resina acetálica autolubrificante
- Profilé en alliage d'aluminium extrudé 6060 T6 UNI 8278 - 100x15 mm
 - Gorge de coulissement: 6 mm
 - Finition superficielle:
peinture polyester blanc RAL 9016 brillant et mat;
peinture polyester noir RAL 9005 brillant et mat;
bronze; anodisé argent; vanille; gris tourterelle
autres couleurs sur demande
 - Poulies en matériau thermoplastique antichoc peint, avec roulettes sur axe en acier
 - Supports en aluminium pour installation murale ou à suspension libre, clavette rotative en métal pour installation au plafond
 - Chevauchement pour rideaux francés 5,5 cm
 - Accessoires en résine d'acétyle autolubrificante
- Rohrwelle aus stranggepresster Aluminiumlegierung 6060 T6 UNI 8278 100x15 mm - Laufkanal: 6 mm
 - Oberflächen-Finish:
Polyesterlackierung Weiß RAL 9016 poliert und matt;
Polyesterlackierung Schwarz RAL 9005 poliert und matt;

Bronze; Alu eloxiert; Vanille; Taubengrau
andere Farben auf Anfrage

- Laufrollen aus lackiertem stoßfestem Thermoplast mit auf Stahlstiften laufenden Rollen
 - Aluminiumhalterungen für die Wandmontage oder freihängende Montage, Drehkeil aus Metall für die Deckenmontage
 - Überlappung für Vorhänge 5,5 cm
 - Zubehör aus selbstgleitendem Acetal
- Profiel van geëxtrudeerde aluminiumlegering 6060 T6 UNI 8278 100x15 mm - Loopkanaal: 6 mm
 - Oppervlakteafwerking: RAL 9016 wit polyester lak gepolijst en mat
RAL 9005 zwart polyester lak gepolijst en mat
brons; zilver geanodiseerd; vanille; duifgrijs
andere kleuren op aanvraag
 - Katrollen van gelakt stootbestendig thermoplast met wielen op stalen pennen
 - Aluminium steunen voor installatie op wand of vrije ophanging, draaibare metalen bevestigingsspie voor installatie op wand
 - Overlappingsprofiel voor plooi gordijnen 5,5 cm
 - Accessoires van zelfsmarend acetal
- Профиль из экструдированного алюминиевого сплава 6060 T6 UNI 8278 - 100x15 мм - Желоб: 6 мм
 - Специальная отделка:
полиэфирная окраска в белый цвет RAL 9016 полированный и матовый;
полиэфирная окраска в черный цвет RAL 9005 полированный и матовый;
бронза; анодирование серебро;
ваниль; серо-коричневый
другие цвета — по запросу
 - Шкивы из противоударного, окрашенного термопласта с колесами на стальных осях
 - Алюминиевые суппорты для настенного или свободного подвешивания, поворотный металлический ключ для потолочной установки
 - Налагающий кронштейн для складчатых штор 5,5 см.
 - Принадлежности из самосмазывающейся ацеталовой пластмассы

ARRESTO MAGNETICO

MAGNETIC STOP

TOPE MAGNÉTICO

SISTEMA MAGNÉTICO DE PARAGEM

BUTÉE MAGNÉTIQUE

MAGNETARRETIERUNG

MAGNETISCHE AANSLAG

МАГНИТНЫЙ СТОПОР



- L'utilizzo dell'art. 4603 permette di determinare il punto di arresto del telo (strappo)
- Art. 4603 can be used to fix the curtain stop point (hand draw system)
- El uso del art. 4603 permite establecer el punto de parada de la tela (tirón)
- A utilização do art. 4603 permite determinar o ponto de paragem da cortina (acionamento à mão)
- L'utilisation de l'art. 4603 permet de déterminer le point d'arrêt du rideau (à la main)
- Die Verwendung von Art. 4603 gestattet die Festlegung des Arretierungspunktes der Stoffbahn (Schleuderzug)
- Het gebruik van art. 4603 staat toe om het aanslagpunt van het doek te bepalen (handmatig)
- Использование арт. 4603 позволяет определить точку остановки полотнища (ручная версия)



1.1.66

Stralys 477

INSTALLAZIONE

INSTALLATION
INSTALACIÓN
INSTALAÇÃO
INSTALLATION
INSTALLATIE
УСТАHOВКА

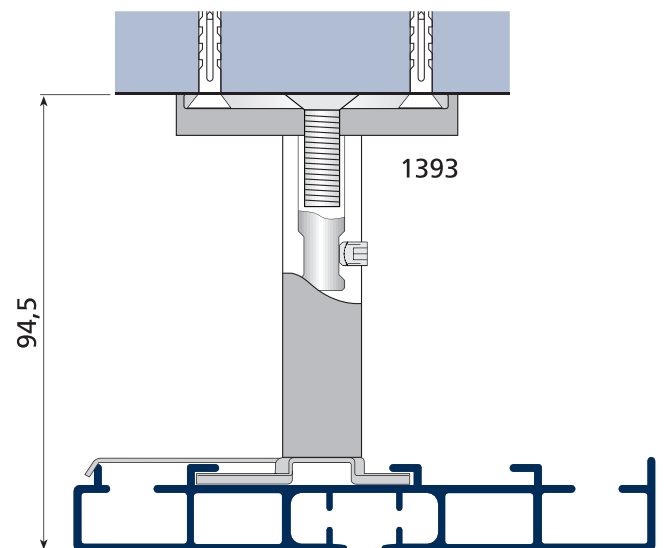
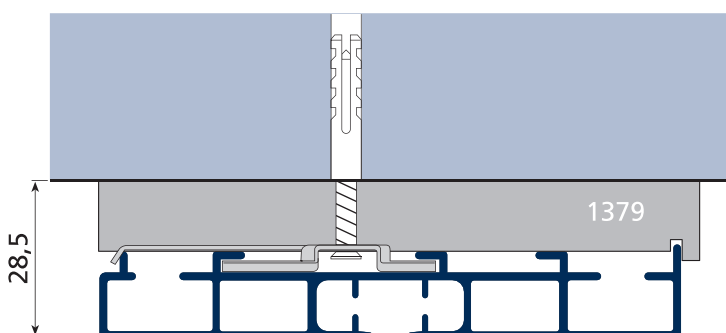
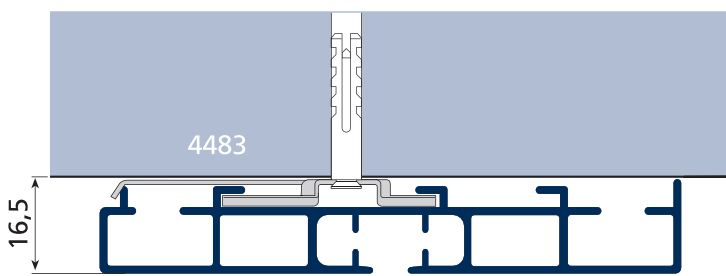
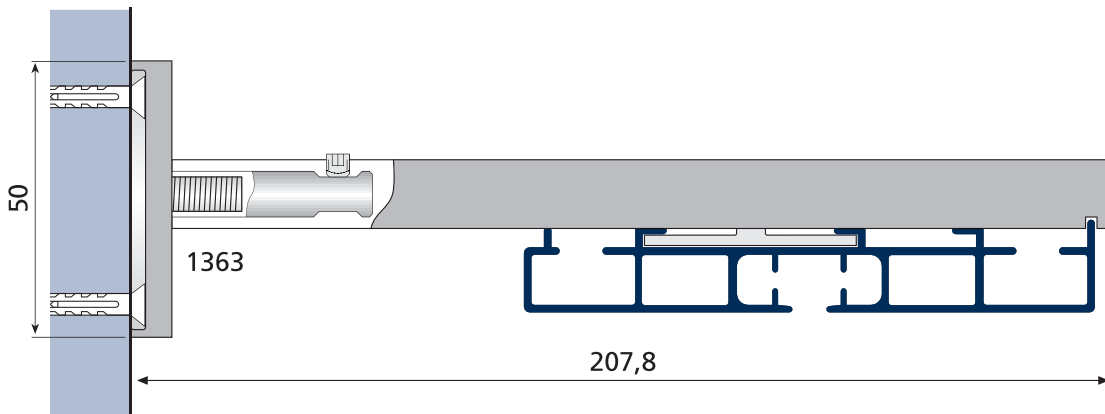
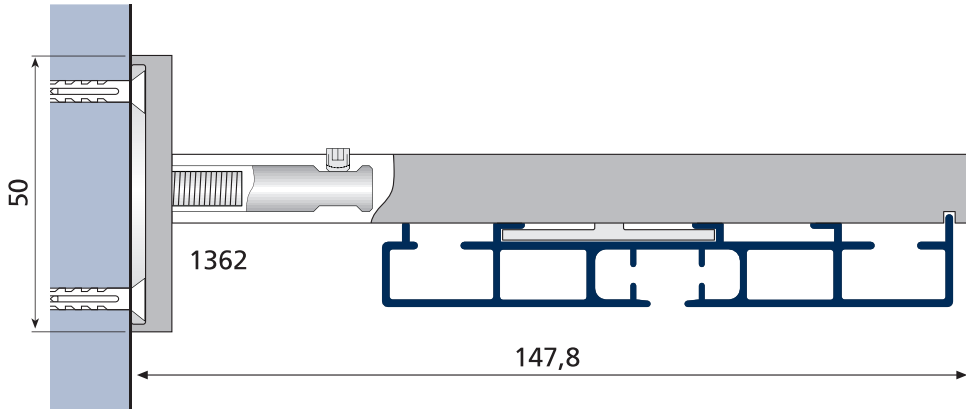

ARRICCIATURA - DRAPING - FRUNCIDO - FRANZIDO
FRONCES - KRÄUSELUNG - PLOOIING - СКЛАДЧАТОСТЬ

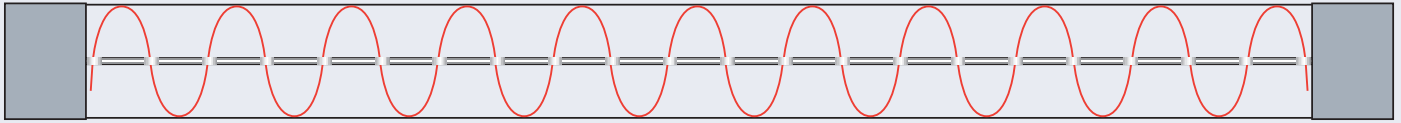

* VALORI INDICATIVI - APPROXIMATE VALUE - VALOR APROXIMADO - VALOR APROXIMADO - VALOR APROXIMADO - VALEUR APPROXIMATIVE - UNGEFÄHRER WERT BENÄDERENDE WAARDE - ПРИБЛИЖЕННОЕ ЗНАЧЕНИЕ

- L'arricciatura continua della tenda è realizzata per mezzo di una corda distanziatrice all'interno del canale di scorrimento degli scivoli
- Continuous curtain draping is achieved by means of a spacer cord inside the channel along which the sliders run.
- El fruncido continuo de la cortina se obtiene mediante una cuerda distanciadora presente en el interior del canal de deslizamiento de las deslizaderas
- O efeito franzido contínuo da cortina é feito por meio de um cordão espaçador dentro da calha de deslizamento dos rodízios.
- Les fronces continues du rideau sont réalisées par le biais d'un cordon d'écartement à l'intérieur de la gorge de déplacement des coulisseaux
- Die durchgängige Kräuselung erfolgt mittels einer Distanzschur im Laufkanal der Gleiter
- De continue plooiing van het gordijn wordt gerealiseerd met behulp van een afstandskoord in het loopkanaal van de runners
- Постоянная складчатость шторы обеспечивается распределительным шнуром внутри желоба скольжения полозков

SPAZIATURA SCIVOLI - SLIDER SPACING SEPARACIÓN DESLIZADERAS - DIST. ENTRE OS RODÍZIOS ESPAC. DES GLISSEURS - GLEITABSTAND SPATIERUNG RUNNERS - РАСПРЕДЕЛЕНИЕ ПОЛОЗКОВ	SPAZIATURA GANCI - HOOK SPACING SEPARACIÓN GANCHOS - DIST. ENTRE OS GANCHOS ESPAC. DES CROCHETS - HAKENABSTAND SPATIERUNG HAKEN - РАСПРЕДЕЛЕНИЕ КРЮЧКОВ	A
		≈ 1:1,7*
		≈ 1:2*
		≈ 1:1,75*
		≈ 1:2*

CONFEZIONI - STYLES OF CURTAINS - TIPOS DE CONFECCIÓN - TIPOS DE CORTINAS
CONFECTION CONSEILLÉE - VORHANGBÄNDER - AANBEVOLEN CONFECTIE - МОДЕЛЬ

	A	B
	≈ 1:1,7 - 1:2	art. 799 - h 75 mm
	≈ 1:1,75 - 1:2	art. 799 - h 75 mm
	1:2	art. 768 - h 30 mm art. 738 - h 65 mm
	1:2	art. 768 - h 30 mm art. 738 - h 65 mm
	1:2	art. 768 - h 30 mm art. 738 - h 65 mm

A

RAPPORTO DI ARRICCIATURA - SPACE BETWEEN THE PLEATS - RAPPORT DE FRUNCIDO - RELAÇÃO DE FRANZIDO - DISTANCE ENTRE PLEIS - GIBT DEN RAFFRAPPORT AN - GEEFT DE AFSTAND TUSSEN DE PLOOIEN AAN - ВИД ДРАПИРОВКИ

B

NASTRO - TAPE - CINTA - FITA - GALON - BAND - LINT - ЛЕHTA



MISURE CONSIGLIATE - MESURES RECOMMANDÉES - EMPFOHLENE MASSNAHMEN - RECOMMENDED MEASURES
 MEDIDAS RECOMENDADAS - MEDIDAS RECOMENDADAS - AANBEVOLEN MAATREGELEN - РЕКОМЕНДУЕМЫЕ РАЗМЕРЫ

APERTURA LATERALE - LATERAL OPENING - APERTURA LATERAL - ABERTURA LATERAL - OUVERTURE LATERAL - EINTEILIG - LATERAAL - БОКОБОЕ

APERTURA CENTRALE - CENTRAL OPENING - APERTURA CENTRAL - ABERTURA CENTRAL - OUVERTURE CENTRAL - 2-TEILIG - CENTRAAL - ЦЕНТРАЛЬНОЕ

APERTURA LATERALE - LATERAL OPENING - APERTURA LATERAL - ABERTURA LATERAL - OUVERTURE LATERAL - EINTEILIG - LATERAAL - БОКОБОЕ

APERTURA CENTRALE - CENTRAL OPENING - APERTURA CENTRAL - ABERTURA CENTRAL - OUVERTURE CENTRAL - 2-TEILIG - CENTRAAL - ЦЕНТРАЛЬНОЕ

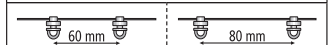
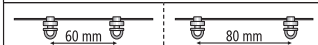
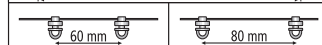
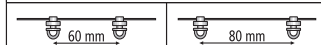
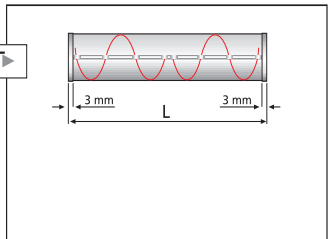
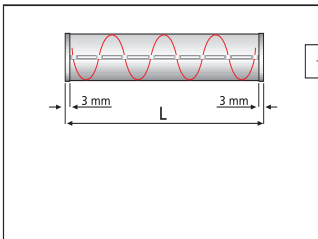
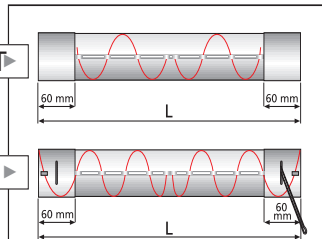
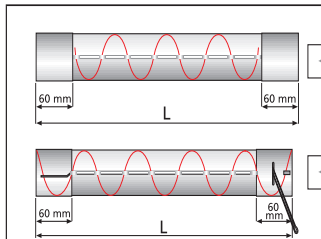

477 ST1	(*)	477 C1	477 ST2	(*)	477 C2
L cm	pz	L cm	L cm	pz	L cm
54	8	46	65	8	58
66	10	58	81	10	74
78	12	70	97	12	90
90	14	82	113	14	106
102	16	94	129	16	122
113	18	105	144	18	137
125	20	117	160	20	153
137	22	129	177	22	169
148	24	141	193	24	185
161	26	153	209	26	201
172	28	164	225	28	216
184	30	176	241	30	232
196	32	188	257	32	248
208	34	200	273	34	264
220	36	212	289	36	280
231	38	223	304	38	295
243	40	235	320	40	311
255	42	247	336	42	327
267	44	259	352	44	343
279	46	271	368	46	359
290	48	283	383	48	374
302	50	295	399	50	390
314	52	306	415	52	406
326	54	319	431	54	422
338	56	331	447	56	438
349	58	342	462	58	453
361	60	353	478	60	469
373	62	365	494	62	485
386	64	377	510	64	501
398	66	389	526	66	517
408	68	400	541	68	533
421	70	412	557	70	549
433	72	424	573	72	565
445	74	437	589	74	581
457	76	449	606	76	597
468	78	460			
480	80	472			
492	82	484			
504	84	496			
516	86	508			
527	88	519			
539	90	531			
551	92	543			
563	94	555			
575	96	567			
586	98	578			
598	100	590			
610	102	604			

477 ST1	(*)	477 C1	477 ST2	(*)	477 C2
L cm	pz	L cm	L cm	pz	L cm
47	8	30	59	8	47
71	12	59	91	12	67
94	16	83	123	16	101
118	20	105	154	20	143
142	24	129	186	24	175
165	28	153	218	28	206
189	32	176	249	32	238
213	36	200	282	36	270
236	40	224	313	40	301
259	44	247	345	44	333
283	48	269	377	48	364
307	52	294	409	52	396
330	56	317	441	56	429
354	60	341	473	60	460
377	64	365	505	64	492
401	68	380	537	68	523
425	72	412	569	72	555
449	76	436	601	76	587
472	80	460			
496	84	484			
519	88	507			
543	92	531			
567	96	555			
590	100	567			

477 ST1	(*)	477 ST2	(*)
L cm	pz	L cm	pz
44	8	58	8
57	10	74	10
68	12	90	12
80	14	106	14
92	16	121	16
104	18	137	18
116	20	153	20
128	22	169	22
140	24	184	24
151	26	200	26
163	28	216	28
175	30	232	30
188	32	247	32
199	34	263	34
211	36	279	36
222	38	295	38
234	40	310	40
246	42	326	42
258	44	342	44
270	46	358	46
281	48	374	48
293	50	389	50
305	52	405	52
317	54	420	54
329	56	436	56
341	58	451	58
352	60	467	60
364	62	483	62
375	64	498	64
387	66	514	66
399	68	530	68
411	70	546	70
422	72	562	72
434	74	577	74
446	76	593	76
458	78		
470	80		
482	82		
493	84		
505	86		
517	88		
529	90		
540	92		
552	94		
564	96		
576	98		
588	100		
600	102		

477 ST1	(*)	477 ST2	(*)
L cm	pz	L cm	pz
37	8	49	8
61	12	80	12
85	16	112	16
108	20	143	20
132	24	174	24
156	28	206	28
179	32	238	32
203	36	269	36
226	40	300	40
250	44	332	44
274	48	364	48
298	52	395	52
322	56	426	56
346	60	458	60
370	64	489	64
393	68	521	68
417	72	553	72
441	76	585	76
464	80		
486	84		
512	88		
536	92		
560	96		
584	100		
596	102		

