

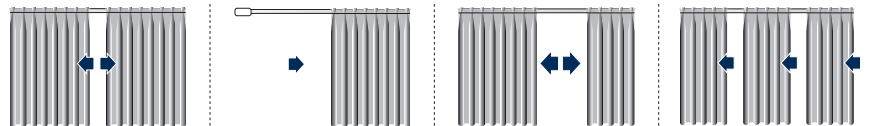

1.1.2

Slalom 430



1:1

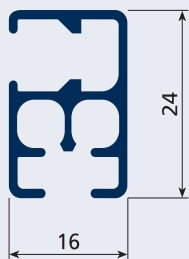

USE

**UTILIZZO - USE - USO
USO - UTILISATION - ANWENDUNG
GEBRUIK - ИСПОЛЬЗОВАНИЕ**

SISTEMA PER TENDE ARRICCIATE AD USO PRINCIPALMENTE DOMESTICO

Azionamento con corde. Indicato per tendaggi L 600 cm max ed H 500 cm di peso non superiore a 5 kg. L'apertura della tenda può essere centrale, laterale, multipla o asimmetrica.

Il sistema è indicato per installazioni a soffitto ed a parete.

Lo scorrimento delle corde d'azionamento in canali indipendenti permette la realizzazione di sistemi curvi a 90° o centinati ad ampio raggio.

Lo scorrimento è garantito da scivoli autolubrificanti in polietilene o da scorrevoli a rullo per i tendaggi al limite della portata.

DRAPED CURTAIN SYSTEM MAINLY FOR DOMESTIC USE

Cord operated. For use with curtains 600 cm W max. and 500 cm H weighing not more than 5 kg. The curtain opening can be central, lateral, multiple or asymmetric.

The system is suitable for ceiling and wall installations.

The running of the operating cords in independent channels allows systems with 90° curves or with wide radius centring to be installed. Sliding is guaranteed by self-lubricating polyethylene slides or by roller gliders for curtains at the load limit.

SISTEMA DE CORTINAS FRUNCIDAS PARA USO PRINCIPALMENTE DOMÉSTICO

Accionamiento mediante cordones. Indicado para cortinas de anchura máx. 600 cm y altura máx. 500 cm y de peso hasta 5 kg. La apertura de la cortina puede ser central, lateral, múltiple o asimétrica.

Este sistema es indicado para montajes tanto en techo como en pared. El deslizamiento de los cordones de accionamiento en canales independientes permite realizar instalaciones curvas en 90° o curvas de amplio ángulo.

El deslizamiento se efectúa mediante correderas deslizantes autolubricadas de polietileno o correderas con ruedecitas para las cortinas más pesadas.

SISTEMA PARA CORTINAS FRANZIDAS PRINCIPALMENTE PARA USO DOMÉSTICO

Accionamento com cordões. Indicado para cortinas com largura máxima de 600 cm, altura 500 cm e peso não superior a 5 kg.

A abertura da cortina pode ser central, lateral, múltipla ou assimétrica. Este sistema é indicado para instalações no tecto

e na parede. O deslizamento dos cordões de accionamento em canais independentes permite instalar sistemas com curvaturas de 90° ou curvaturas de raios amplos. O deslizamento é garantido por deslizadores de polietileno autolubrificantes ou por corredeiras de rolos para cortinas no limite do peso.

SYSTÈME POUR RIDEAUX DRAPÉS À USAGE PRINCIPALEMENT DOMESTIQUE

Actionnement par drisses. Préconisé pour rideaux L 600 cm max. et H 500 cm d'un poids maximum de 5 kg.

L'ouverture du rideau peut être centrale, latérale, multiple ou asymétrique. Ce système est indiqué pour installation au plafond et de face. Le coulisement des drisses d'actionnement dans des rails indépendants permet la réalisation de systèmes courbés à 90° ou cintrés à grand rayon. Le coulisement est assuré par glissières autolubrifiantes en polyéthylène ou par rouleurs pour les rideaux atteignant le poids maximum autorisé.

WORHANGSYSTEM ÜBERWIEGEND FÜR DEN PRIVATEN HAUSHALT

Schnurbetätigung. Für Gardinen mit max. L 600 cm und H 500 cm, Gewicht höchstens 5 kg.

Mögliche Öffnungsarten: 2-teilig, einteilig, mehrteilig oder asymmetrisch. Das System ist für Decken- und Wandmontage geeignet. Durch das Gleiten der Betätigungsschnüre in unabhängigen Kanälen können im 90°-Winkel gebogene Systeme oder Systeme mit großem Radius ausgeführt werden. Selbstschmierende Polyethylenleiter und Rollgleiter für Gardinen, deren Gewicht fast an der Tragfähigkeitsgrenze liegt, gewährleisten einwandfreies Gleiten.

GORDIJNSYSTEEM VOORNAMELIJK VOOR PRIVAAT GEBRUIK





Koordbediend. Te gebruiken voor gordijnen van maximum 600 cm breed en 500 cm hoog, met maximum gewicht van 5 kg.

Pakket: centraal, lateraal, meervoudig of asymmetrisch. Het systeem kan tegen de wand of tegen het plafond geplaatst worden. De koorden bevinden zich in aparte koordkanalen, waardoor de rail op 90° of op grote straal kan worden verbogen. Het glijden is gegarandeerd door zelfsmurende polyethylenglijders of door rollers voor gordijnen aan het limietgewicht.

СИСТЕМА ДЛЯ Д+ОР ПРЕИМУЩЕСТВЕННО ДЛЯ БЫТОВОГО ИСПОЛЬЗОВАНИЯ

Приведение в действие шнурами. Рекомендуется для штор Д. 600 см макс. и В. 500 см, весом не более 5 кг. Открытие шторы может быть центральным, боковым, в нескольких точках и несимметричным. Эта система рекомендуется для потолочных и настенных установок. Движение шнуров по независимым желобам позволяет выполнять системы с поворотом на 90° или же с большим радиусом.

Движение осуществляется посредством самосмазывающихся полозков из полиэтилена или роликовых бегунков для штор, вес которых приближается к максимальному.

Kg ref. 4263											Kg ref. 4263										
	2m	4m	6m	8m	10m	12m	14m	16m	18m	20m		2m	4m	6m	8m	10m	12m	14m	16m	18m	20m
	7,5 Kg	9 Kg	5 Kg									3 Kg	4 Kg	2 Kg							
	6 Kg	7 Kg	4 Kg									3 Kg	4 Kg	2 Kg							



1.1.4

Slalom 430



CARATTERISTICHE TECNICHE - SPECIFICATIONS CARACTERÍSTICAS - CARACTERÍSTICAS - CARACTÉRISTIQUES EIGENSCHAFTEN - KARAKTERISTIEKEN - ХАРАКТЕРИСТИКИ

- Profilo in lega d'alluminio estrusa 6060 T6 UNI 8278
 - Larghezza 16 mm - Altezza 24 mm
 - Canale di scorrimento 6 mm
 - Raggio di curvatura minima:
curve a 90°: 12 cm - curve ad ampio raggio: 50 cm
 - Finiture superficiali:
verniciatura poliester bianco RAL 9016 lucido
verniciatura poliester nero RAL 9005 lucido
bronzo; argento anodizzato; oro anodizzato
altri colori a richiesta
 - Carrucole in acciaio
 - Carrucole in termoplastico antiurto con ruote su perni in acciaio
 - Sormonto in acetilica autolubrificante da 5,5 cm
 - Accessori in acetilica autolubrificante
-
- 6060 T6 UNI 8278 extruded aluminium alloy track
 - Width 16 mm - height 24 mm
 - Sliding channel 6 mm
 - Minimum radius of curvature 90° curves: 12 cm;
wide radius curves: 50 cm
 - Surface finishes: RAL 9016 white polyester paint polished;
RAL 9005 black polyester paint polished;
bronze; silver and gold anodised;
available on request
 - Steel pulleys
 - Shockproof thermoplastic pulleys with wheels on steel journals
 - 5.5. cm self-lubricating acetylic overlap
 - Self-lubricating acetylic accessories
-
- Perfil en aleación de aluminio extruido 6060 T6 UNI 8278
 - Anchura 16 mm - Altura 24 mm - Canal de deslizamiento 6 mm
 - Ángulo de curvatura mínima: curvas en 90°: 12 cm curvas de ángulo amplio: 50 cm
 - Acabados de la superficie: pintura poliéster blanca RAL 9016 brillante;
pintura poliéster negra RAL 9005 brillante;
bronce; anodizado plata y oro;
otros colores bajo petición.
 - Polea de acero - polea de termoplástico endurecido con ruedas sobre ejes de acero.
 - Sobreposición de acetálico autolubrificante de 5,5 cm
 - Accesorios de acetálico autolubrificante
-
- Perfil de liga de alumínio extrudido 6060 T6 UNI 8278
 - Largura 16 mm - Altura 24 mm
 - Calha de deslizamento 6 mm
 - Raio de curvatura mínimo:
curvas de 90°: 12 cm - curvas de raio amplo: 50 cm
 - Acabamentos superficiais:
tinta de poliéster branca RAL 9016 polido
tinta de poliéster preta RAL 9005 polido
bronze; anodizado prateado e dourado
outras cores a pedido
 - Polias de aço
 - Polias de material termoplástico anti-choque com rodas aplicadas em pernos de aço
 - Sobreposição de resina acetálica autolubrificante de 5,5 cm
 - Acessórios de resina acetálica autolubrificante

- Profil en alliage d'aluminium extrudé 6060 T6 UNI 8278
 - Largeur 16 mm - Hauteur 24 mm
 - Rail de coulissement 6 mm
 - Rayon minimum - courbes à 90°: 12 cm courbes grand rayon: 50 cm
 - Finition superficielle:
peinture polyester blanc RAL 9016 brillant;
peinture polyester noir RAL 9005 brillant;
bronze; anodisé argent et or
autres couleurs sur demande
 - Poulies en acier
 - Poulies en matériau thermoplastique antichoc avec roues sur pivots en acier.
 - Croisement en résine d'acétal autolubrificante de 5,5 cm
 - Accessoires en résine d'acétal autolubrificante
-
- Profil aus extrudierter Alu-Legierung 6060 T6 UNI 8278
 - Breite 16 mm - Höhe 24 mm - Laufkanal 6 mm
 - Kleinster Biegeradius 90°-Kurven: 12 cm mit großem Radius: 50 cm
 - Oberflächen-Finish:
Polyesterlackierung Weiß RAL 9016 poliert;
Polyesterlackierung Schwarz RAL 9005 poliert;
Bronze - Alu eloxiert - Gold eloxiert;
andere Farben auf Anfrage
 - Umlenkrollen aus Stahl
 - Umlenkungen aus stoßfestem Thermoplast mit Rollen auf Stahlbolzen
 - Überlappung aus selbstschmierendem Acetal 5,5 cm
 - Zubehör aus selbstschmierendem Acetal
-
- 6060 T6 UNI 8278 geëxtrudeerd aluminium profiel
 - Breedte 16 mm - hoogte 24 mm - Kanaalbreedte 6 mm
 - Minimum buigradius voor 90° verbuiging: 12 cm, voor grote verbuiging: 50 cm
 - Afwerking: RAL 9016 wit polyester lak glanzend
RAL 9005 zwart polyester lak glanzend
brons; zilver geanodiseerd; goud geanodiseerd
andere kleuren op aanvraag
 - Staal poelies
 - Schokbestendige thermoplastische poelies met wielen op metalen as
 - Overlapbeugel 5,5 cm
-
- Профиль из экструдированного алюминиевого сплава 6060 T6 UNI 8278
 - Ширина 16 мм - Высота 24 мм
 - Желоб 6 мм
 - Минимальный радиус поворота:
повороты на 90°: 12 см - повороты с большим радиусом: 50 см
 - Отделка поверхности:
полиэфирная окраска в белый цвет RAL 9016 полированный
полиэфирная окраска в черный цвет RAL 9005 полированный
бронза; анодирование серебро; анодирование золото
другие цвета - по запросу
 - Стальные шкивы
 - Шкивы из противоударного термопласта с колесами на стальных осях
 - Налегающий кронштейн из самосмазывающейся ацеталовой пластмассы 5,5 см
 - Принадлежности из самосмазывающейся ацеталовой пластмассы

INSTALLAZIONE

INSTALLATION
 INSTALACIÓN
 INSTALAÇÃO
 INSTALLATION
 INSTALLATION
 INSTALLATIE
 УСТАНОВКА

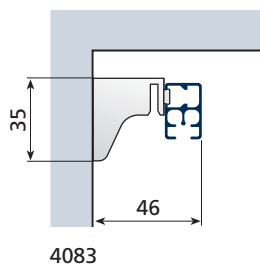

4083

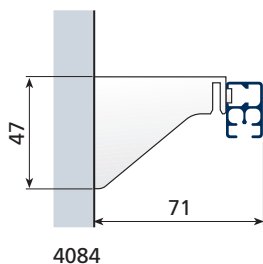

4084

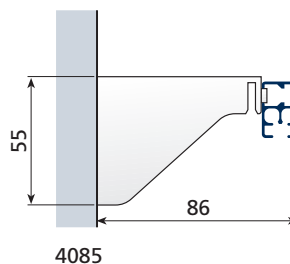

4085

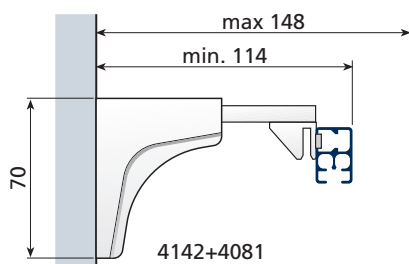

4142+4081

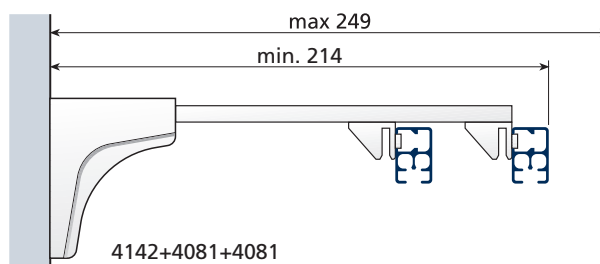

4142+4081+4081

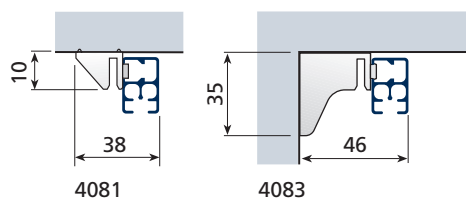

4081

4083

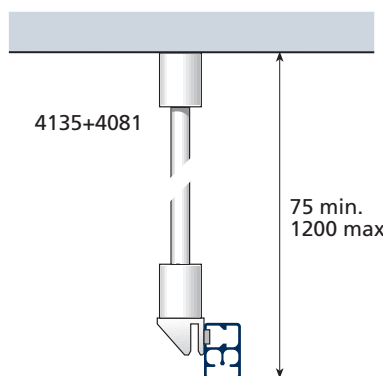

4135+4081

75 min.
1200 max

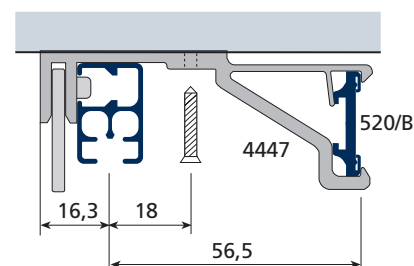

4447

520/B



4080

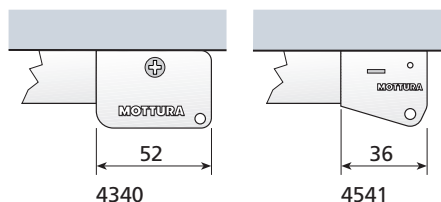

4340

4541

CURVE

BENDING
 CURVAS
 CURVAS
 COURBAGE
 BOGEN
 BUIGEN
 ИЗГИБ

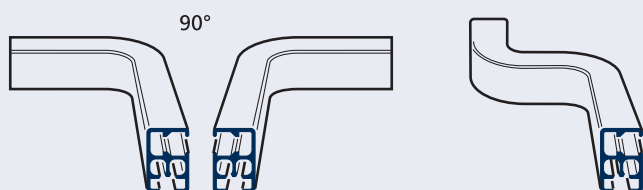

90°



max 90°
R. 12 cm



art. 9813 (Sec. C)



art. 9801/9802/9806
(Sec. C)

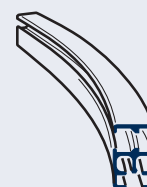
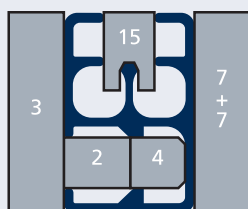

art. 9814 (Sec. C)



art. 9805 (Sec. C)

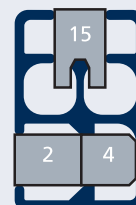



1.1.6

Slalom 430

CARRUCOLE

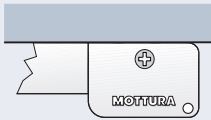

4340+4182+4184



max 6 kg

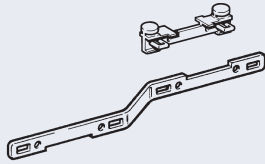

PULLEYS
POLEAS
POLIA
POULIES
ÜBERLAUFWAGEN
POELIES
БЛОКИ

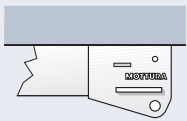

4541+4185



max 3 kg

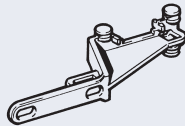

POSIZIONAMENTO SUPPORTI

SUPPORT POSITIONING
DISTANCIA ENTRE SOPORTES
POSIÇÃO DOS SUPORTES
POSITION DES SUPPORTS
ANBRINGUNG DER HALTERUNG
POSITIE VAN DE STEUNEN
РАЗМЕЩЕНИЕ КРОНШТЕЙНОВ

L cm



140	1
141 → 200	2
201 → 280	3
281 → 340	4
341 → 480	5
481 → 600	6



CARRUCOLA INTERMEDIA

INTERMEDIATE RETURN PULLEY
POLEA INTERMEDIA
POLIA CENTRAL
POULIE CENTRALE

ZWISCHENUMLENKER
CENTRALE POELIE
ЦЕНТРАЛЬНЫЙ БЛОК

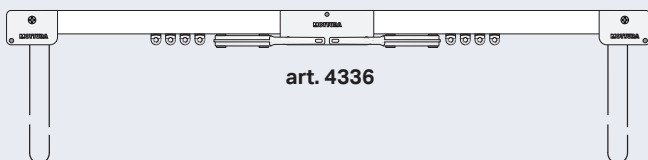
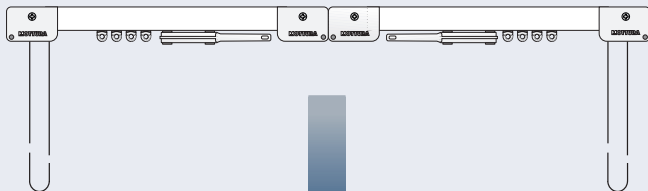

art. 4336

CONFEZIONI CONSIGLIATE

A RAPPORTO DI ARRICCIATURA
THE SPACE BETWEEN THE PLEATS
RAPPORT DE FRUNCIDO
RELAÇÃO DE FRANZIDO
INDIQUE LA DISTANCE ENTRE PLIS
GIBT DEN RAFFRAPPORT AN
GEEFT DE AFSTAND TUSSEN DE PLOEIEN
AAN
ВИД ДРАПИРОВКИ

SUGGESTED STYLES OF CURTAINS
TIPOS DE CONFECCIÓN
TIPOS DE CORTINAS ACONSELHADOS
CONFECTION CONSEILLÉE
EMPFOHLENE VORHANGBÄNDER
AANBEVOLEN CONFECTIE
МОДЕЛЬ

B NASTRO - TAPE
CINTA - FITA
GALON - BAND
LINT - ЛЕНТА

	A	B
	1:2	art. 761 - h 70 mm
	1:1,5	art. 773 - h 90 mm art. 387
	1:2	art. 773 - h 90 mm art. 387
	1:2	art. 761 - h 70 mm
	1:2	art. 761 - h 70 mm
	1:3	art. 780 - h 90 mm art. 773 - h 90 mm art. 387
	1:3	art. 773 - h 90 mm art. 387

SCIVOLI

GLIDERS
CORREDERAS
DESILIZADORES
GLISSEURS

GLEITER
GLIJIDERS
БЕГУЩИ
БЕГУЩИ

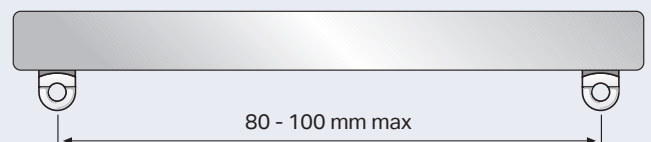

80 - 100 mm max

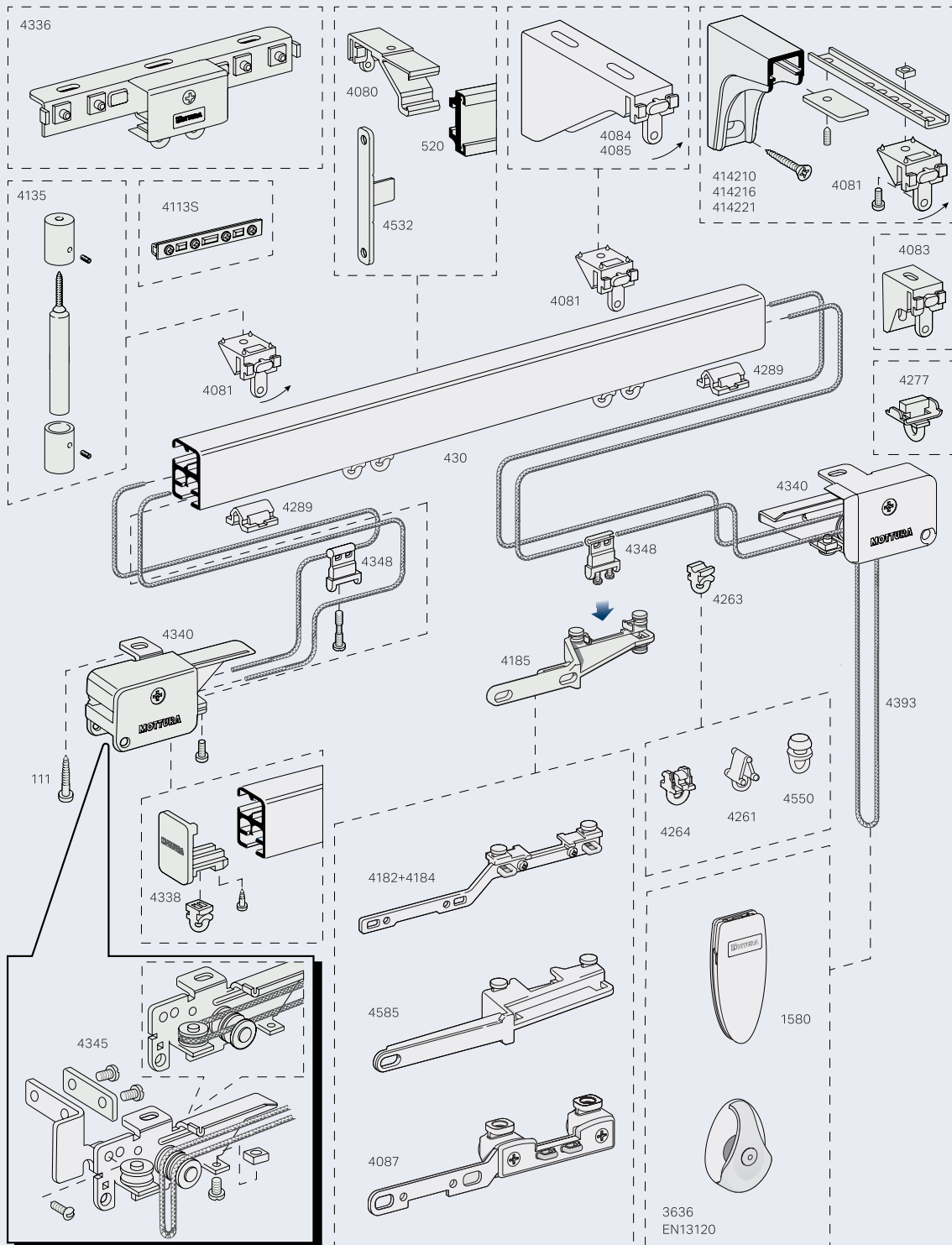

SISTEMAZIONI - APPLICATION - COLOCACIÓN - APLICAÇÕES - MONTAGE - MONTAGE - TOEPASSING - ВАРИАНТЫ УСТАНОВКИ

